



No. 2 1974

issued quarterly

Technical Review

To Advance Techniques in Acoustical, Electrical and Mechanical Measurement

Signal/Noise of Tape Recorders • Vibratory Influence on Tape Recorders

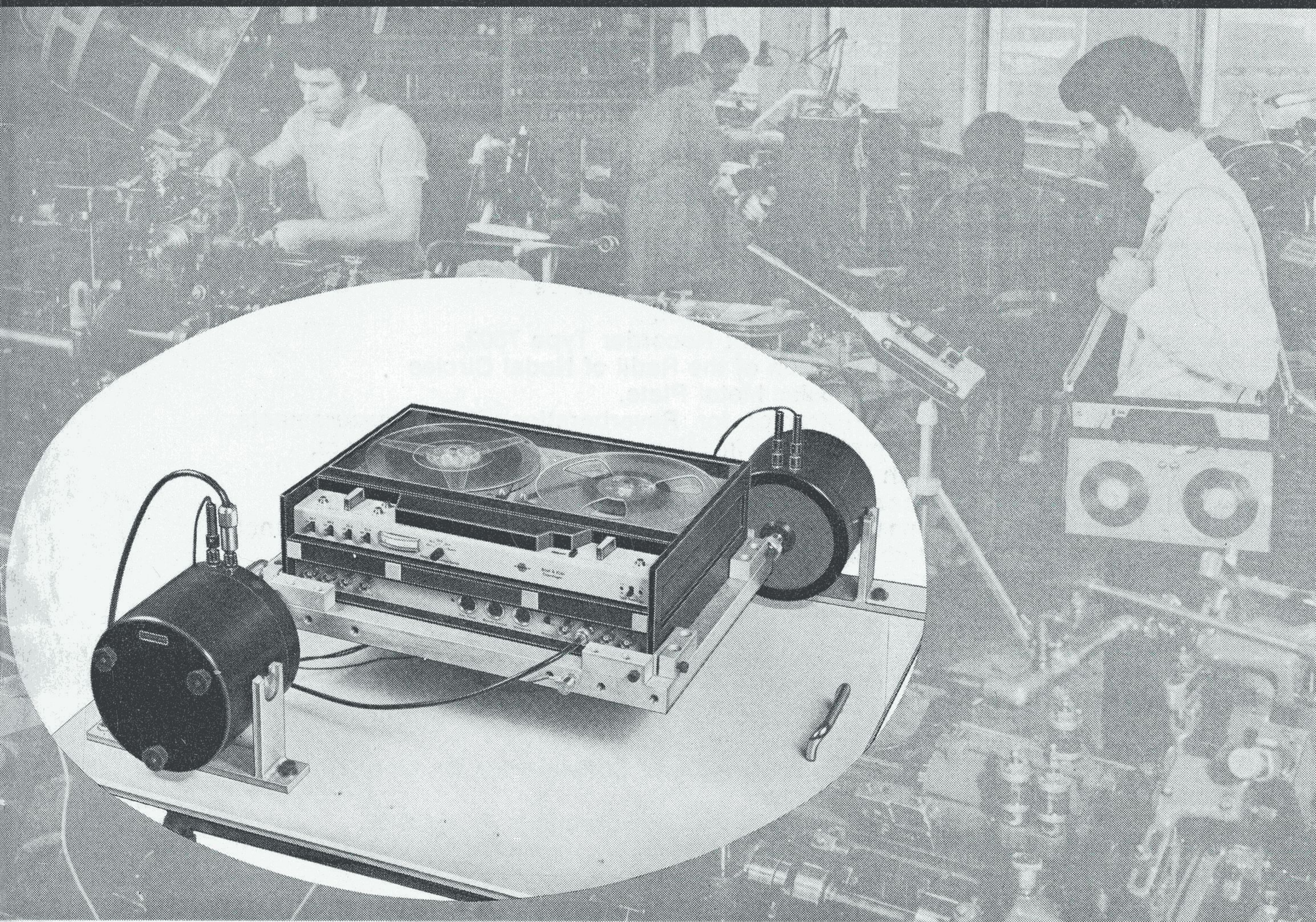

BRÜEL & KJÆR

**PREVIOUSLY ISSUED NUMBERS OF
BRÜEL & KJÆR TECHNICAL REVIEW**

- 1-1974 Measurements of averaging times of Level Recorders Types 2305 and 2307.
A simple Equipment for direct Measurement of Reverberation Time using Level Recorder Type 2305.
Influence of Sunbeams striking the Diaphragms of Measuring Microphones.
- 4-1973 Laboratory tests of the Dynamic Performance of a Turbocharger Rotor-Bearing System.
Measurements on the Resonance Frequencies of a Turbocharger Rotor.
- 3-1973 Sources of Error in Noise Dose Measurements.
Infrasonic Measurements.
Determination of Resonance Frequencies of Blades and Disc of a Compressor Impeller.
- 2-1973 High Speed Narrow Band Analysis using the Digital Event Recorder Type 7502.
Calibration Problems in Bone Vibration with reference to IEC R 373 and ANSI S3. 13-1972.
An Investigation of the Near Field Screen Efficiency for Noise Attenuation.
- 1-1973 Calibration of Hydrophones.
The Measurement of Reverberation Characteristics.
Adaptation of Frequency Analyzer Type 2107 to Automated 1/12 Octave Spectrum Analysis in Musical Acoustics.
Bekesy Audiometry with Standard Equipment.
- 4-1972 Measurement of Elastic Modulus and Loss Factor of Asphalt.
The Digital Event Recorder Type 7502.
Determination of the Radii of Nodal Circles on a Circular Metal Plate.
New Protractor for Reverberation Time Measurements.
- 3-1972 Thermal Noise in Microphones and Preamplifiers.
High Frequency Response of Force Transducers.
Measurement of Low Level Vibrations in Buildings.
Measurement of Damping Factor Using the Resonance Method.
- 2-1972 RMS-Rectifiers.
Scandiavian Efforts to Standardize Acoustic Response in Theaters and Dubbing Rooms.
Noise Dose Measurements.
- 1-1972 Loudness Evaluation of Acoustic Impulses.
Computer Programming Requirements for Acoustic Measurements.
Computer Interface and Software for On-Line Evaluation of Noise Data.
Evaluation of Noise Measurements in Algol-60.

(Continued on cover page 3)

TECHNICAL REVIEW

No. 2 — 1974

Contents

On Signal/Noise Ratio of Tape Recorders by H. C. Hansen	3
On the Operating Performance of the Tape Recorder Type 7003 in a Vibrating Environment by H. P. Olesen	13
News from the factory	26

On Signal/Noise Ratio of Tape Recorders

by

H. C. Hansen

ABSTRACT

One of the most significant and commonly used performance characteristic for comparison between tape recorders is the signal to noise ratio. However, specification of this value is often ambiguous, unless the test procedure used for its measurement is specified. In this article, the different test procedures used for instrumentation and audio tape recorders are briefly described, as well as the parameters influencing the signal to noise ratio.

SOMMAIRE

L'une des caractéristiques les plus significatives et les plus couramment utilisées pour comparer les enregistreurs magnétiques est le rapport signal à bruit. Cependant, l'indication de ce paramètre est souvent ambiguë, à moins que la procédure utilisée pour la mesure soit indiquée. Dans cet article, on décrit brièvement les différentes procédures d'essai utilisées pour les enregistreurs magnétiques d'instrumentation et enregistreurs audio, et on discute les paramètres qui influencent le rapport signal à bruit.

ZUSAMMENFASSUNG

Einer der wichtigsten und meist verwendeten Vergleichskennwerte für die Beurteilung von Magnetbandgeräten ist das Signal/Rausch-Verhältnis, auch Störspannungsabstand genannt. Die Angabe dieses Wertes ist jedoch häufig sehr fragwürdig, wenn nicht gleichzeitig die benutzte Meßmethode angegeben wird. Dieser Artikel beschreibt kurz die unterschiedlichen Meßmethoden, die für Meß-Magnetbandgeräte und für normale Tonbandgeräte verwendet werden, wie auch die Parameter, die den Störspannungsabstand beeinflussen.

Introduction

Tape recorders today are used extensively over a broad field of applications, ranging from the original recording of sound to instrumentation recording and digital tape recording. Because of the inherent advantages of tape recording, this way of storing information will undoubtedly be dominating for quite a number of years to come. Much technical progress has been made up to now, especially regarding frequency response, tape economy and signal/noise ratio.

The study of various tape recorder data sheets often leaves the reader rather doubtful as to the evaluation of the given information. One of the main characteristics of a tape recorder is specified by its signal-to-noise ratio. Because this figure may vary considerably depending on the test procedure it is important to investigate the specification and determine why the figures vary so much (the total range may exceed 30 dB) from one tape recorder to another. Also the term "signal-to-noise ratio" should be adhered to rather than "dynamic range" the latter often being used as a synonym for the first and sometimes (more correctly) meaning the dynamic range for signals to be recorded and later distinguished from the inherent tape recorder noise. Thus tape recorders using compander* circuits show greater dynamic range than signal-to-noise ratio.

Tape Recorder Categories

First of all, it is necessary to distinguish the types of tape recorders that are dealt with. Much confusion may occur, if different categories of tape recorders are directly compared, mainly because their varied applications call for different test procedures. The two main groups of tape recorders to be considered are: instrumentation tape recorders and audio tape recorders.

Instrumentation recorders are used for recording and analysis of data with the aid of objective instruments, and therefore the greatest possible accuracy is required. Since audio recorders, however, are intended for listening purposes only, the demands to precision for such recorders are less imperative.

Both groups may be analog tape recorders although different recording techniques are generally involved. In the following each kind will be investigated separately and the reasons for the normally accepted test procedures will be discussed.

Instrumentation Tape Recorders

The aim of these recorders is to provide a registration and storage capacity for data to be analyzed. It is desirable to give as few restrictions as possible for data to be handled and to offer a high degree of precision in accordance with the state of the art. For these reasons more complex methods of recording are often used, for instance FM- or pulse recording. The drawbacks of such systems (besides their initial higher costs) are poorer tape economy and high frequency limitations. Instrumentation systems based on direct recording technique are made to overcome

* Compander = Compressor/Expander

these difficulties at the cost of precision and signal-to-noise ratio. It should be noted that because frequency analysis is often carried out on the stored data, information about the 1/3 octave or narrow band noise spectrum of a tape recorder may be useful in determining its suitability for a given registration.

Since the signal/noise ratio measured by a 1/3 octave filter or a narrow band filter may exceed the linear signal/noise ratio by more than 20 dB, signals can be detected and analyzed even if their levels are considerably below the total linear noise level.

For instrumentation tape recorders, fortunately, a widely accepted way of specifying data is found in the Telemetry Standard, Document 106-66*, of the Inter-Range Instrumentation Group, mostly referred to IRIG Standard. In this standard the procedure for measuring the signal-to-noise ratio of instrumentation recorders is also given. The noise measurement differs slightly between "FM-recorders" and "direct recorders". For the first type the noise is measured with an average reading, RMS calibrated voltmeter, whereas the direct recorder noise is measured with an RMS reading meter RMS calibrated. Both measurements are unweighted and the noise readings in both cases are referred to the output voltage at normal recording level. Normal recording level for FM recorders is obtained at $\pm 40\%$ carrier deviation whereas for direct recorders, normal recording level is the level that causes a third harmonic distortion of 1% at a signal frequency of 500 Hz (HF-bias setting procedure is stipulated as well).

Evidently signal-to-noise measurements carried out according to the IRIG standard may be compared, however, it should be stressed that before using the figures for a quality comparison one should make sure that other parameters such as tape speed and frequency range are equal. According to the IRIG standard, recorders are divided into subgroups depending on their frequency range: lowband, intermediate band and wide band recorders (see Table 1). This means that if a low band tape recorder, at a given tape speed, has an upper limiting frequency of f_0 , then an intermediate band recorder, at the same tape speed, has an upper limiting frequency of $2 f_0$ and a wide band recorder extends the range to $4 f_0$ or even $20 f_0$, depending on the wide band group. The IRIG-table shown deals with FM tape recorders. A somewhat similar table exists also for "direct" tape recorders. As in general the noise

* Revised February 1969

Tape Speed (ips)				
Low Band	Intermediate Band	Wide Band Group I	Carrier Center Frequency kHz	Modulation Frequency kHz
1 — 7/8			1,688	DC to 0,313
3 — 3/4	1 — 7/8		3,375	DC to 0,625
7 — 1/2	3 — 3/4		6,750	DC to 1,250
15	7 — 1/2	3 — 3/4	13,50	DC to 2,500
30	15	7 — 1/2	27,00	DC to 5,000
60	30	15	54,00	DC to 10,00
	60	30	108,0	DC to 20,00
	120	60	216,0	DC to 40,00
		120	432,0	DC to 80,00
		Wide Band Group II	Carrier Center Frequency kHz	Modulation Frequency kHz
		3 — 3/4	28,125	DC to 12,50
		7 — 1/2	56,250	DC to 25,00
		15	112,50	DC to 50,00
		30	225,0	DC to 100,0
		60	450,0	DC to 200,0
		120	900,0	DC to 400,0

Table 1. Carrier frequencies and modulation bandwidths for FM tape recorders extracted from the IRIG standard

spectrum is approximately "white" for FM recorders, i.e. the noise energy per Hz bandwidth is constant within the pass band of the recorder, therefore doubling of the upper limiting frequency will reduce (theoretically) the signal/noise ratio by 3 dB. In practice this figure varies because of other factors influencing the signal-to-noise ratio, but generally speaking, the recorder with the widest frequency range should be expected to exhibit the poorest signal to noise ratio. Direct recording tape recorders show a similar relationship between frequency range and signal/noise ratio although their noise spectra deviate from that of white noise on account of equalisation, i.e. increased amplification at very low and very high frequencies.

Also, in the case of direct recorders the track width of the tape should be taken into consideration. In general doubling the track width results in a 3 dB better signal-to-noise ratio. The track configurations are also standardized by the IRIG document. On account of the strict measuring procedures outlined by IRIG, in general, it is possible to compare instrumentation tape recorders. In case of audio tape recorders, however, such comparison is often very difficult with respect to the signal-to-noise ratio.

Audio Tape Recorders

As indicated by the group designation, these recorders are intended to store and reproduce the audible frequency range, preferably with a maximum fidelity as interpreted by the human ear. The signal-to-noise ratio is one of the most important factors for determining the quality of an audio tape recorder, and hence the factors influencing this specification should be considered.

Because of the varying ear sensitivity with audio frequency and level, a linear noise measurement does not supply sufficient information as to how annoying the measured noise will act on a listener. Attempts have therefore been made to design a suitable weighting curve for the noise spectrum in order to create an objective means to measure the effect of noise on the human ear. The most commonly used methods of noise measurements are:

1. RMS, A-weighted according to IEC-179
2. "Quasi peak" measurement, weighted as per DIN 45 405
3. RMS measurement, weighted as above (DIN 45 405). This is in accordance with CCITT recommendation, P. 53 (1960)

The two weighting curves are shown in Fig.1 and Fig.2. As can be seen they both cause an attenuation of the low frequencies and the highest

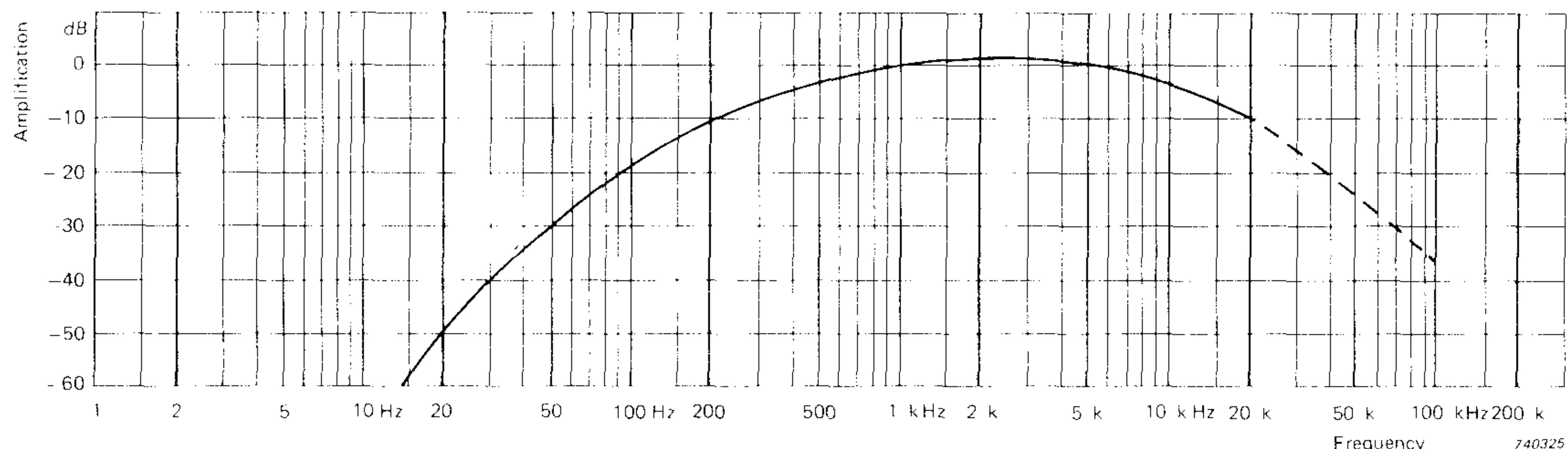

Fig. 1. The weighting curve according to IEC-179

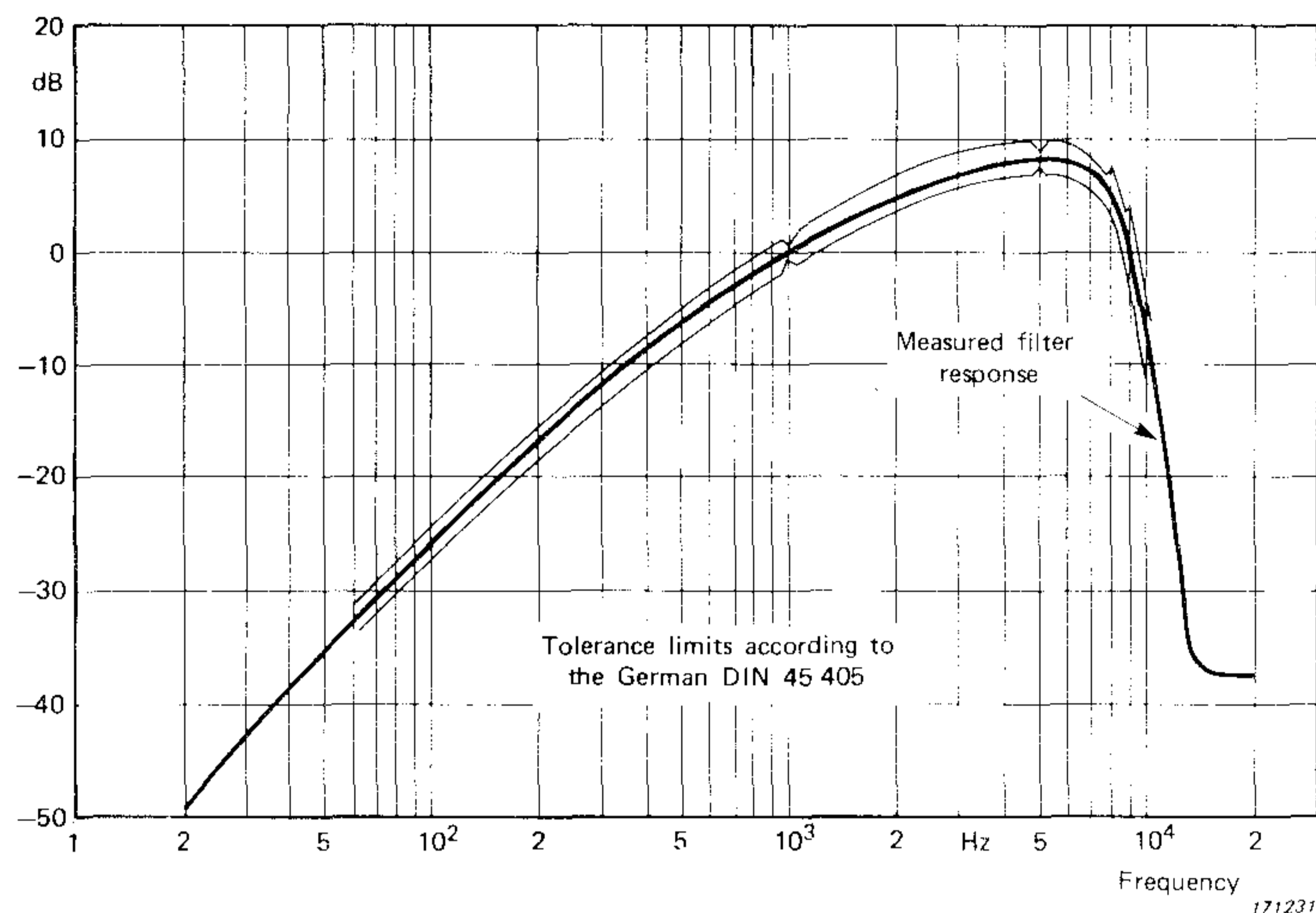

Fig.2. Weighting curve according to DIN 45 405

frequencies relative to the medium frequency range. The important difference is that the DIN 45 405 curve — also named psophometric curve — gives an amplification in the range 1 to 9 kHz, that is this filter has to be used in connection with an amplifier. The effect on the signal-to-noise ratio when comparing methods 1 and 3 depends on the noise spectrum to be measured. Normally, however, using the A-weighting will provide about 4 to 6 dB better signal-to-noise ratio than would be obtained by using the method according to CCITT. Measurement according to 2 will typically give approximately 6 dB higher noise figures than measurement according to 3 because of the crest factor of the noise.

Often one of these measurements are supplemented by a linear noise measurement comprising the audio frequency range. (20 — 20 000 Hz).

Apart from the noise measurement a reference recording level has to be set in order to calculate the signal-to-noise figure. Unfortunately, different reference levels are being used. Some manufacturers state the DIN test tape recording level (320 pWb per mm track width) as reference level, others refer to recording level set by a certain amount of third harmonic distortion, normally 1,5%, 2% or 3%. Evidently the latter is related to a certain type of tape as well as to the bias setting criterion.

Other factors which affect the signal-to-noise ratio of audio recorders are the frequency range and the track width as already mentioned for instrumentation recorders. The tape speed also plays a role since at lower tape speeds the necessary amount of equalisation has to be increased in order to cover the audible frequency range. This means that

more amplification at higher frequencies is necessary and consequently tape noise and amplifier noise is emphasized as well.

The choice of tape should not be overlooked. The tape market offers a wide selection of tapes and when optimum performance is to be obtained it is imperative to select the best tape for this purpose. As a rule audio tape recorders will offer best signal-to-noise ratio when using low noise, high output audio tapes. A gain of approximately 3 dB over ordinary audio tapes is normal. In this connection it should be stressed that using instrumentation tapes on audio tape recorders normally results in a poorer signal-to-noise ratio at a considerably higher price. This is due to the fact that instrumentation tapes have very thin and highly-polished coatings enabling very short wavelengths to be recorded, but the maximum recording level at medium wavelengths (audio frequencies) may be as much as 10 dB lower than would be the case for high output audio tapes. In general, instrumentation tapes are made with much narrower tolerances — mechanically and magnetically — than audio tapes, but these advantages are hardly noticeable for listening purposes.

In view of the above remarks it can be seen that immediate comparison of the signal-to-noise ratio of audio recorders is only possible when all relevant information as to the measuring methods is available and as, often, this is not the case the only safe procedure is to have directly comparable measurements carried out.

Audio Recorders and Direct Recording Instrumentation Recorders

A comparison between the linear signal-to-noise ratio of an instrumentation recorder using direct recording technique and that of an audio recorder will unveil a significant difference in favour of the audio tape recorder although the latter may be far the most low priced of the two. Consequently some explanation is appropriate and the basic principles of direct tape recording technique should therefore be considered. For direct tape recording the tape magnetization is proportional to the voltage of the information to be recorded. When a recording with a constant record current (i.e. current through record head coil) is carried out using a suitable HF — bias current, the reproduction of the recording in terms of reproduce head output voltage is shown in Fig.3, curve a.

For low and medium frequencies the output increases with frequency at 6 dB/oct. according to the induction law $e = k \cdot \frac{d\Phi}{dt}$, where e is the voltage, Φ is the tape flux passing through the head coil and t is time. At higher frequencies the output still increases though less rapidly than the theoretical curve due to a number of physical limitations. These are

the necessary amount of amplification at high frequencies, as this leads to simultaneous amplification of the inherent tape noise which has approximately the character of white noise. Consequently this pre-emphasis will deteriorate especially the linear signal-to-noise ratio greatly. Of course, the weighted noise curve is also adversely affected and therefore audio technicians looked for a possible improvement. As it is known that a normal sound frequency spectrum (speech or conventional music) contains substantial power at low to medium frequencies it seemed permissible to introduce some degree of pre-emphasis of the high frequencies i. e. instead of making constant current recordings, the record current was increased at high frequencies. The effect of the pre-emphasis can be seen in Fig.3 and Fig.4, dotted curves(b). It might be mentioned that a small degree of pre-emphasis of the very lowest frequencies is also used, but it must be stressed that the involvement of pre-emphasis is only allowable for applications where the power frequency spectrum is known to have the "audio shape". This is in general not the case for instrumentation tape recorders. Also it should be noted that as a consequence of pre-emphasis the frequency response of an audio tape recorder must be measured at a lower level than that corresponding to maximum recording level at medium frequencies in order to avoid overloading of tape at high frequencies. Normally a -20 dB level is suggested. Although the pre-emphasis in recordings explain the improvement in signal-to-noise ratio there are other factors as well. An audio tape recorder is in general designed to deal with the audible frequency range whereas an instrumentation recorder often accepts 1 or more extra octaves towards high frequencies and therefore its signal-to-noise ratio is reduced as explained previously.

Closely related to the frequency range considerations is the construction of magnetic heads, especially the reproduce heads. Instrumentation heads have to be constructed with very narrow gaps and special core profiles in order to deal with very short wavelengths on tape. Also the coil resonance frequencies of these heads must lie octaves higher than for the case of audio magnetic heads. This results in significantly lower output from reproduce heads of the instrumentation tape recorders at the same frequency and tape speed and consequently higher reproduction amplification is required. As a result noticeable amplifier noise is generated in addition to the general tape noise which has already been regarded.

The maximum recording level on tape depends on the amount of distortion that can be accepted. For instrumentation recorders — as mentioned previously — a third harmonic distortion of 1% (according to IRIG)

is accepted at maximum recording level on tape. In case of audio tape recorders a somewhat higher distortion is normally permitted, often 2 or 3%, and as a consequence the maximum recording level can be increased by approximately 3 dB and the signal-to-noise ratio gets the full benefit thereof.

The HF-bias setting procedure is established by IRIG in a way that optimises the ability to record short wavelengths on tape at the expense of the maximum recording level at medium wavelengths. For audio tape recorders, on the other hand, the HF-bias is chosen with more respect to the output level at medium frequencies. Often the HF-bias is adjusted to give almost maximum output level at 1 kHz. The result again is a higher (3 — 5 dB) level at medium frequencies for audio tape recorders than for instrumentation recorders.

As the track width of audio recorders often exceeds the track width of multichannel instrumentation recorders, a better signal-to-noise ratio results for the former type.

Conclusion

The problem of evaluation of the signal-to-noise ratio of a tape recorder by studying the technical data sheet only, may not always be so simple at first sight. First and foremost consideration should be given to what measuring procedure is used or which standard lies behind the presented figure, and secondly it is equally important to know the category of the recorder under consideration. Bearing in mind the main factors that influence the signal-to-noise ratio, an objective evaluation of the tape recorder will be achieved.

On the Operating Performance of the Tape Recorder Type 7003 in a vibrating environment

by

H. P. Olesen

ABSTRACT

To determine the effects of vibrational environment on the operation of tape recorders, a test recording was played back and the flutter level measured of the Tape Recorder Type 7003, while it was subjected to vibration in three mutually perpendicular directions successively at various acceleration levels. The tape recorder was also subjected to torsional vibrations around the vertical axis.

To set the measured values into perspective the results were compared to those obtained from another precision tape recorder. The lower flutter levels obtained for the 7003 would seem to be partly due to the use of the differential capstan drive principle.

SOMMAIRE

Pour étudier les effets d'un environnement vibratoire sur le fonctionnement des enregistreurs magnétiques, on a relu un enregistrement test sur un Enregistreur Magnétique Type 7003 et mesuré le scintillement en soumettant l'appareil à des vibrations, successivement dans trois directions mutuellement perpendiculaires, avec différents niveaux d'accélération. L'enregistreur a également été soumis à des vibrations en torsion autour de l'axe vertical.

On a comparé les résultats avec ceux obtenus sur un autre enregistreur magnétique de précision. Le scintillement plus faible noté pour le 7003 semble dû en partie à l'emploi du système d'entraînement à cabestan différentiel.

ZUSAMMENFASSUNG

Um den Einfluß von Vibrationen auf das Betriebsverhalten von Magnetbandgeräten zu bestimmen, wurde ein Testband abgespielt. Die Gleichlaufwerte (Flutter) wurden gemessen, wobei das Bandgerät in drei zueinander senkrechten Richtungen Nacheinander mit verschiedenen Beschleunigungspegeln angeregt wurde. Zusätzlich wurde das Gerät auch Torsionsschwingungen um die senkrechte Achse ausgesetzt.

Um die gemessenen Werte beurteilen zu können, wurden diese mit den Meßwerten eines anderen Präzisions-Magnetbandgerätes verglichen. Die dabei festgestellten geringen Gleichlaufschwankungen des Typ 7003 sind auf die Verwendung eines Differential-Capstanantriebs zurückzuführen.

Introduction

Portable Tape Recorders for instrumentation purposes must often operate in unfavourable vibrational environment when recordings are taken in the field. To determine the influence of vibration on performance, flutter analysis was carried out on a Tape Recorder Type 7003, while it was being vibrated in the X, Y and Z axes successively as well as in rotation around the Z axis. For comparison purposes similar measurements were carried out on another precision tape recorder (Make X).

The measurement procedure

A test tape for each tape recorder was prepared on which a constant frequency signal for each tape speed tested was recorded in separate recording channels. The frequencies for these signals were chosen to be the measuring frequencies of the flutter meter used. For the Tape Recorder Type 7003, the frequencies were 54 kHz and 3,38 kHz for 15 in/s and 1,5 in/s respectively. As 54 kHz is the normal carrier frequency for the 7003 at 15 in/s this frequency was obtained by short circuiting the input of the tape recorder while recording. The frequency of 3,38 kHz at 1,5 in/s was obtained by the application of a DC offset at the input.

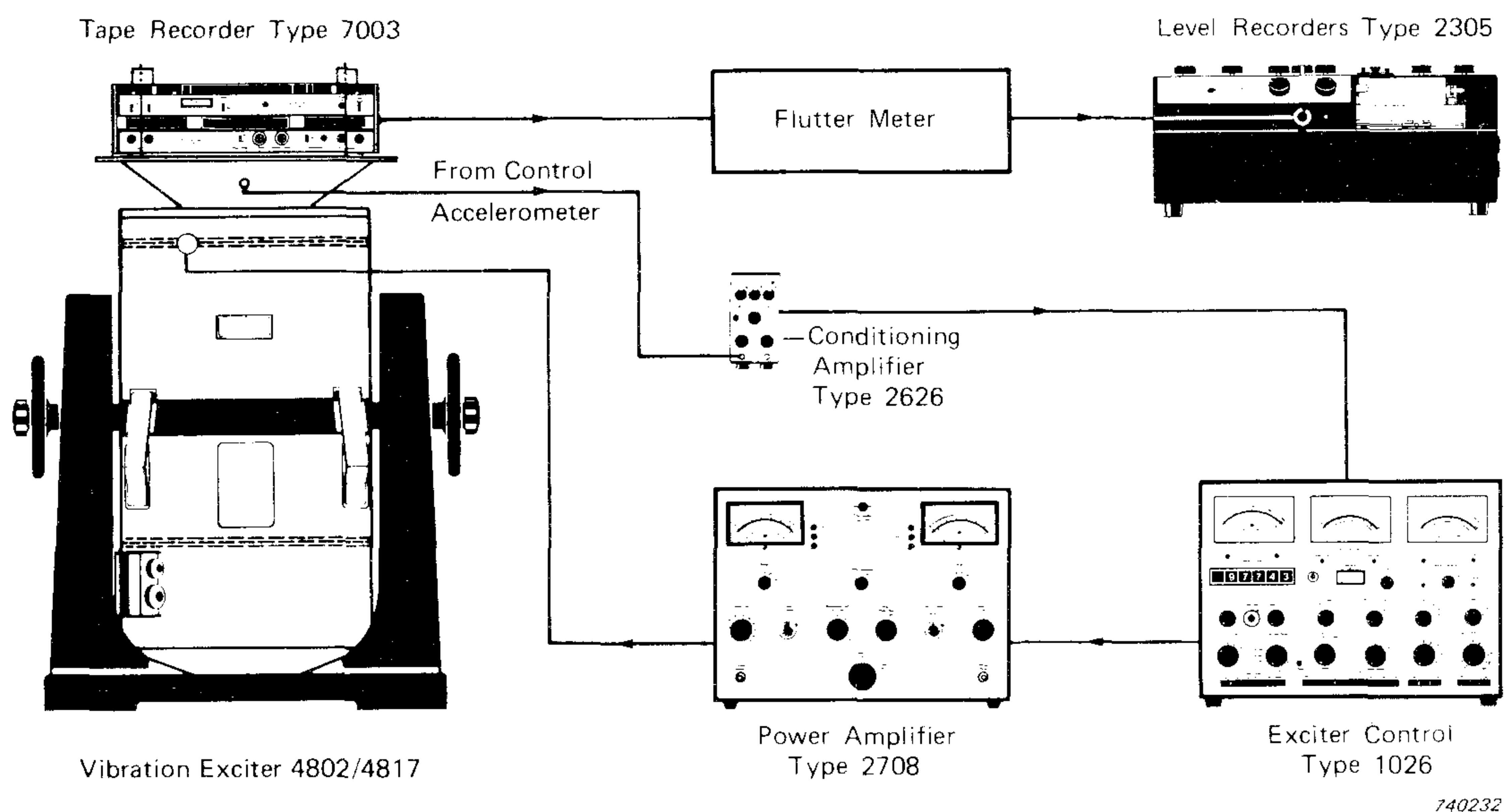

Fig.1. Measurement arrangement for flutter measurements while the Tape Recorder Type 7003 is being vibrated

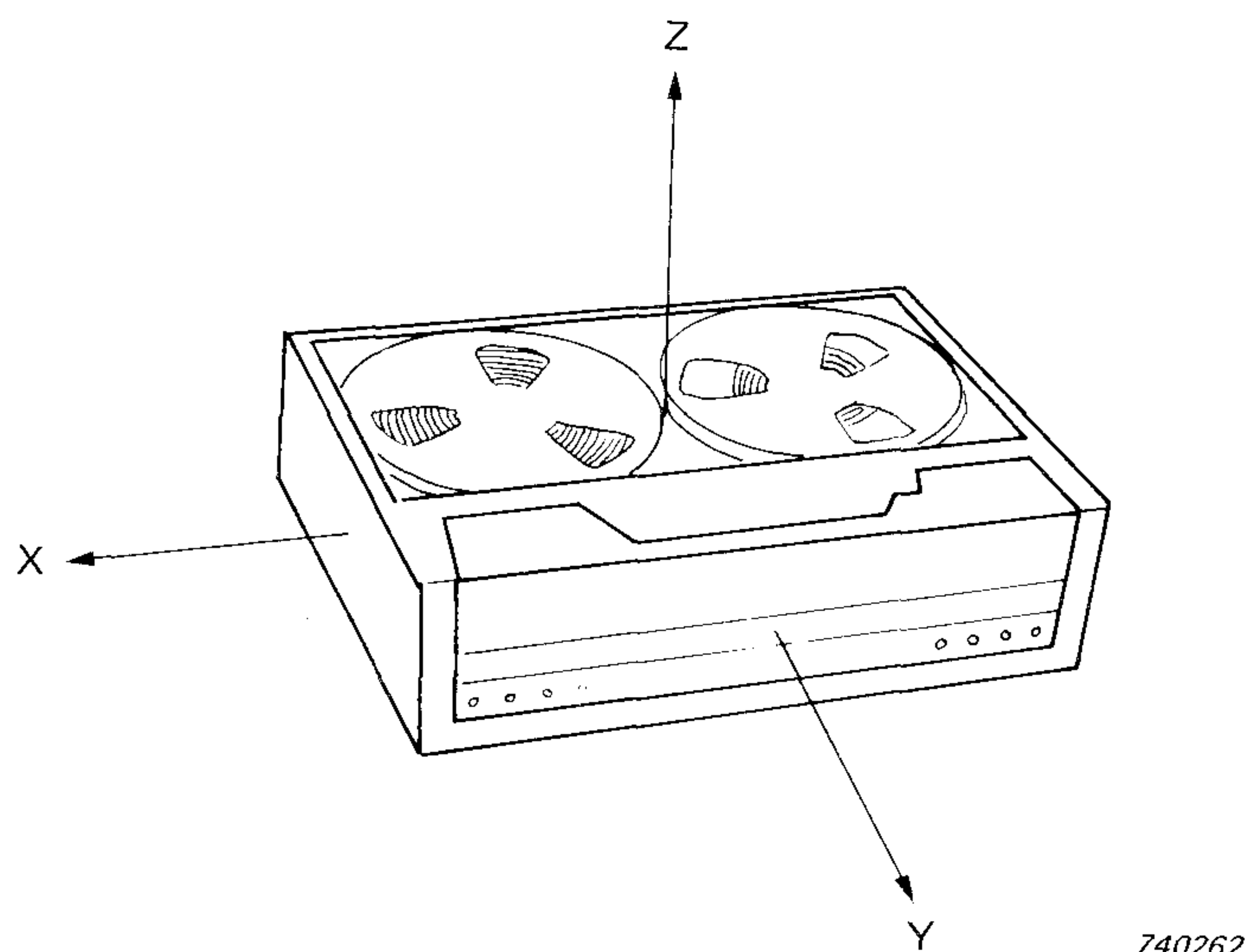

Fig.2. The three axes of vibration of the tape recorder

The signals from the played back tape were taken before FM-demodulation to the flutter meter, and the flutter was measured with bandwidths specified by the IRIG Standard (2,5 kHz and 313 Hz for 15 in/s and 1,5 in/s respectively). The flutter signal was taken to a Level Recorder Type 2305 and recorded as a function of vibration excitation frequency.

The rectilinear vibration tests were carried out with a Vibration Exciter Type 4802 with associated control instruments and with a vibration fixture which has the fundamental resonance at approximately 950 Hz. The arrangement is shown in Fig.1, and Fig.2 indicates the three axes of vibration.

The rotational tests were carried out on a rotatable fixture driven by two Vibration Exciters Type 4809 as shown in the photograph Fig.3. The vibration level was controlled by means of a control accelerometer placed on the edge of the fixture at a distance of 12 cm from the Y axis shown in Fig.4. As the maximum angle of rotation is very small ($\pm 0,02$ rad or $1,15^\circ$) the angular acceleration is determined from the linear acceleration measured, by

$$\ddot{\alpha} = \frac{a \times 9,81}{l} = \frac{a \times 9,81}{0,12} \quad \text{rad/s}^2$$

where a is the acceleration measured in g units. Although the fixture had relatively large vertical cross motions at some frequencies (Fig.5) it did not seem to influence the result of flutter measurements.

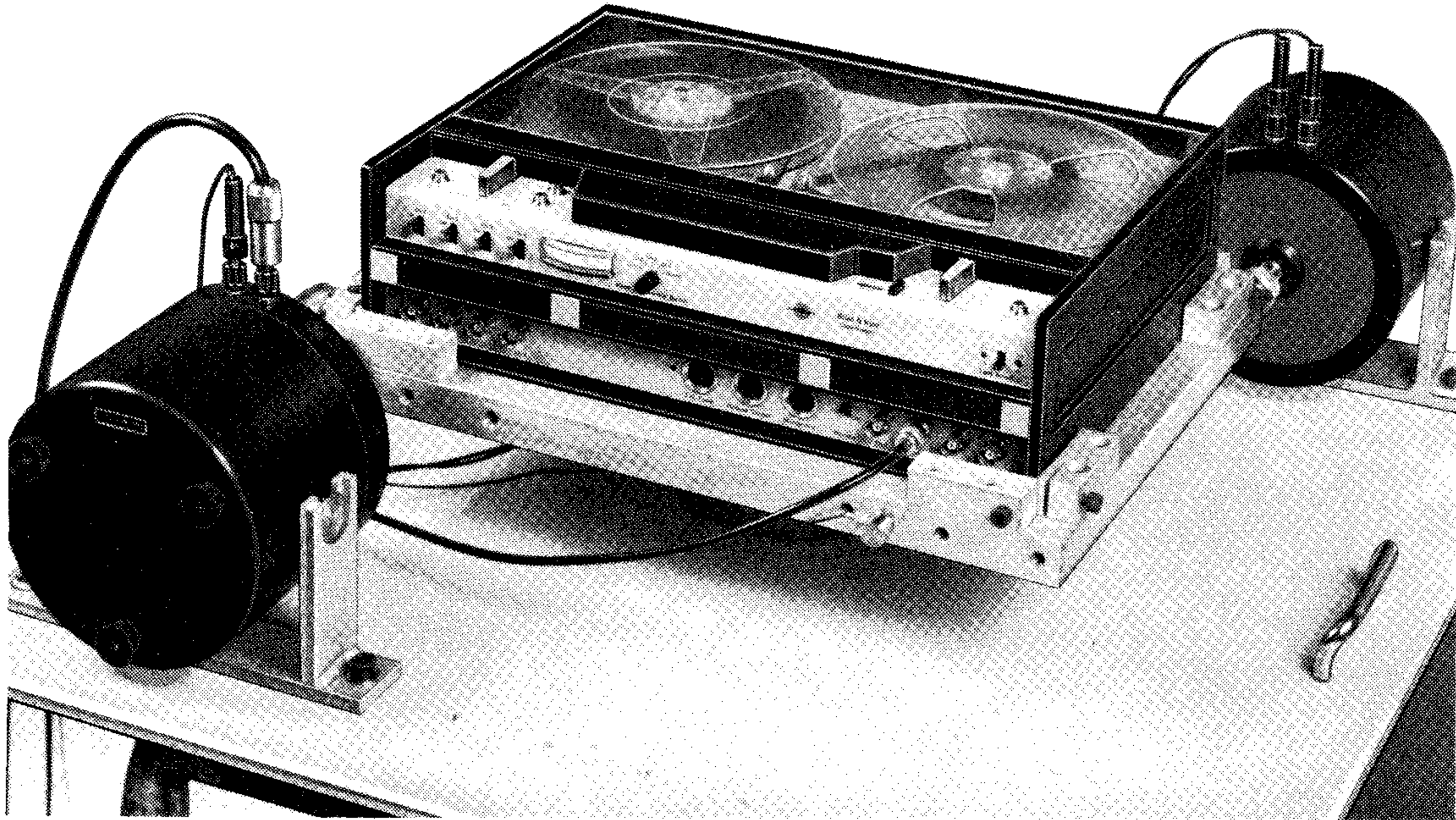

Fig.3. Photograph of the Tape Recorder Type 7003 being vibrated on the rotatable fixture

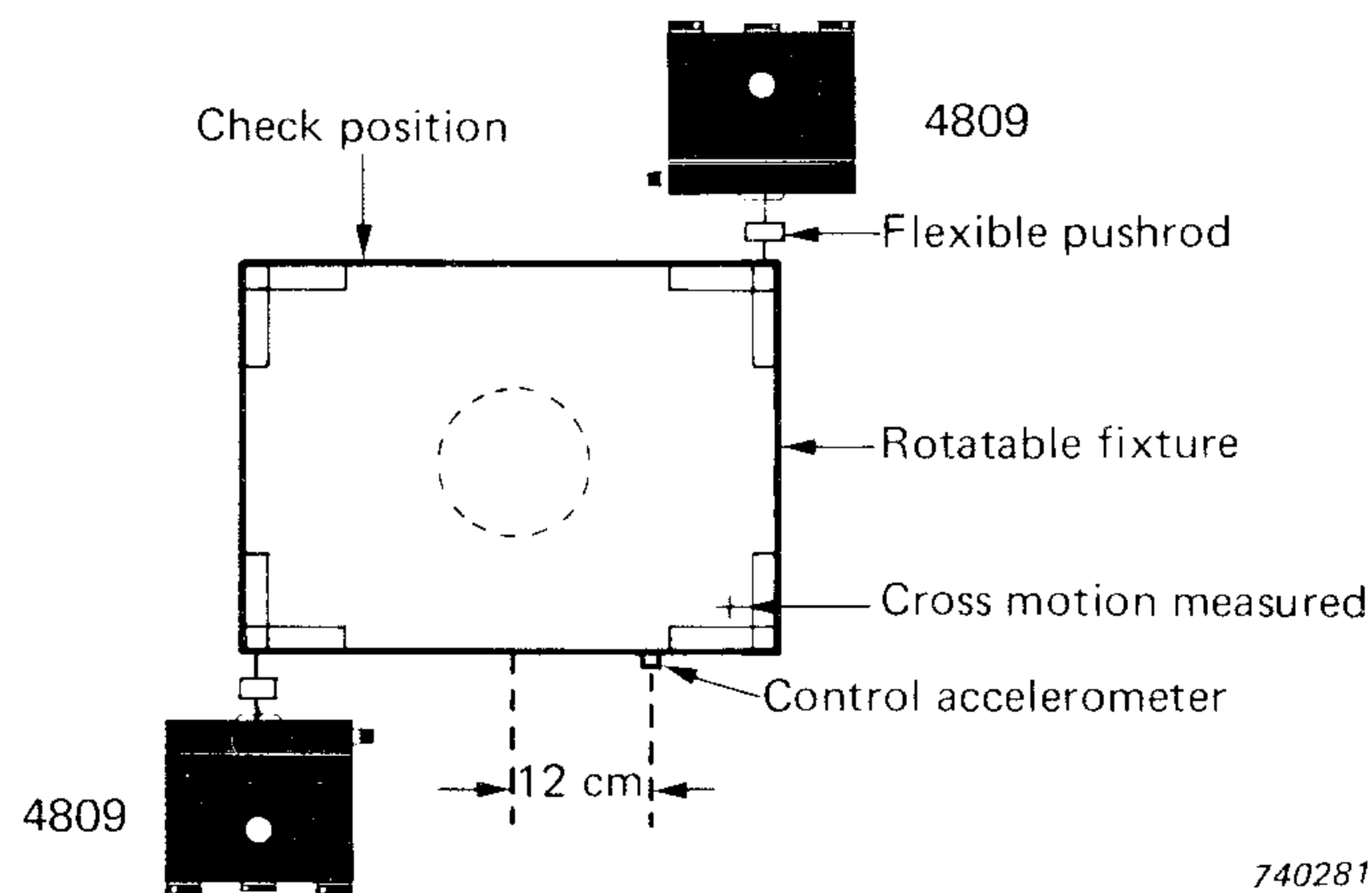

Fig.4. Sketch of the vibration measurement points

Measurements of amplitude and phase (Fig.6a and Fig.6b) from an accelerometer placed diagonally across the fixture from the control accelerometer revealed disturbances at 75 Hz and just over 100 Hz. By a careful study of the flutter measurements, no significant effects of these disturbances could be detected. Disregarding the cross motions and the disturbances, which were partly caused by the lack of a stable support the fixture operated satisfactorily in the torsional mode up to approxi-

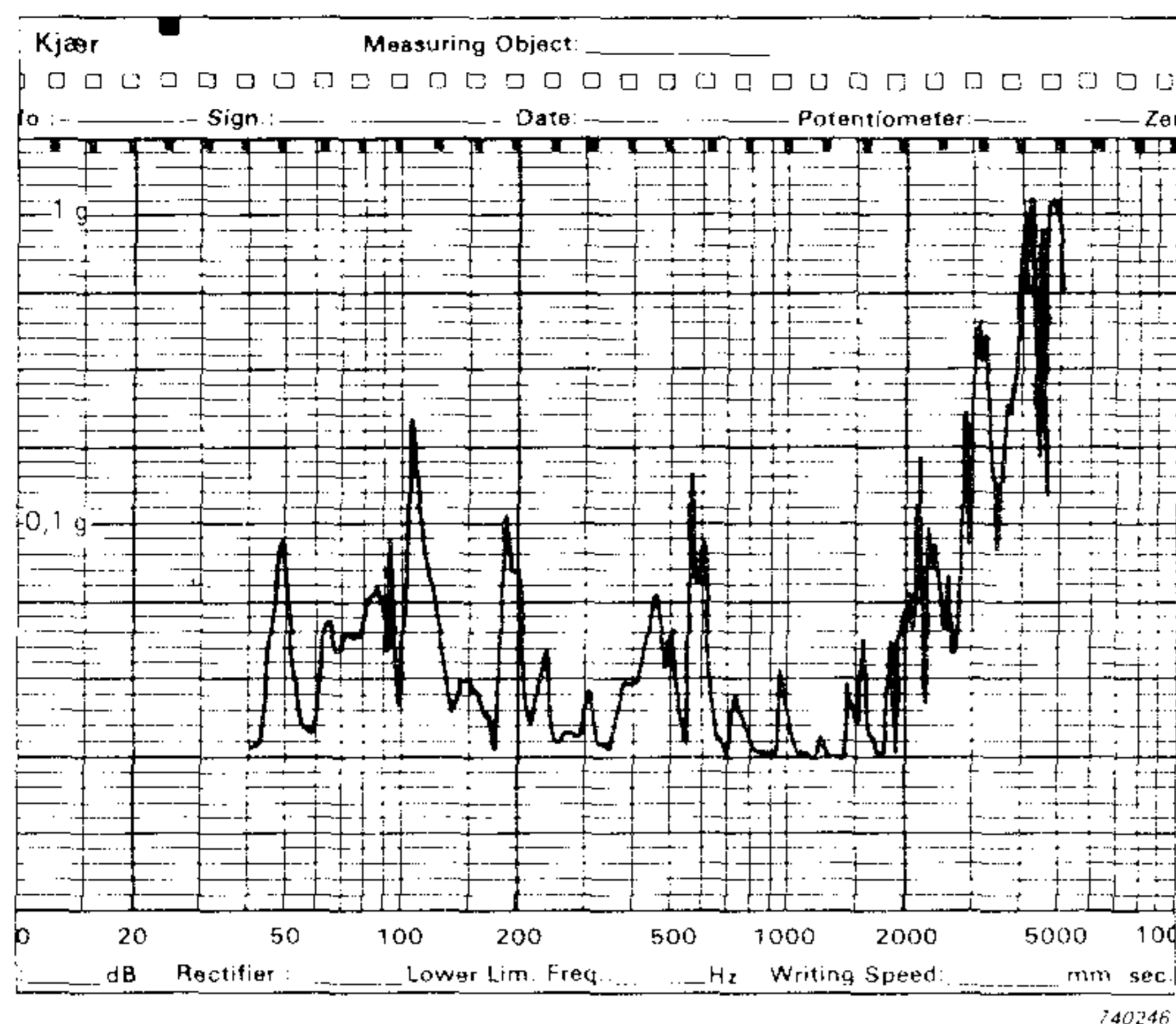

Fig.5. Vertical cross motion measured on the extreme corner of the rotatable fixture for a torsional vibration level of 16 rad/s^2

mately 800 Hz as required for the flutter measurements. However, useful operation could be performed up to approximately 2000 Hz as seen from the amplitude and phase curves.

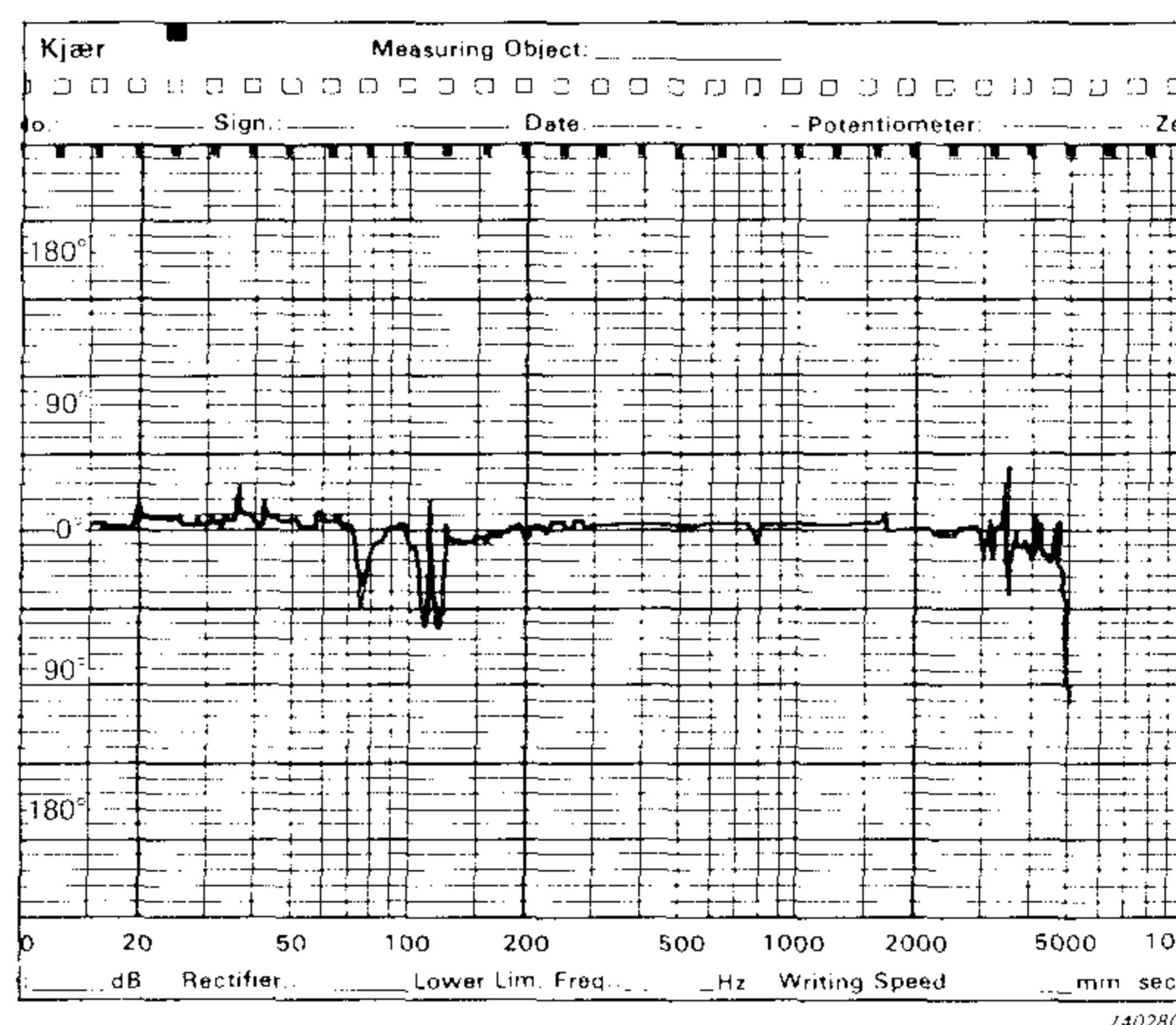
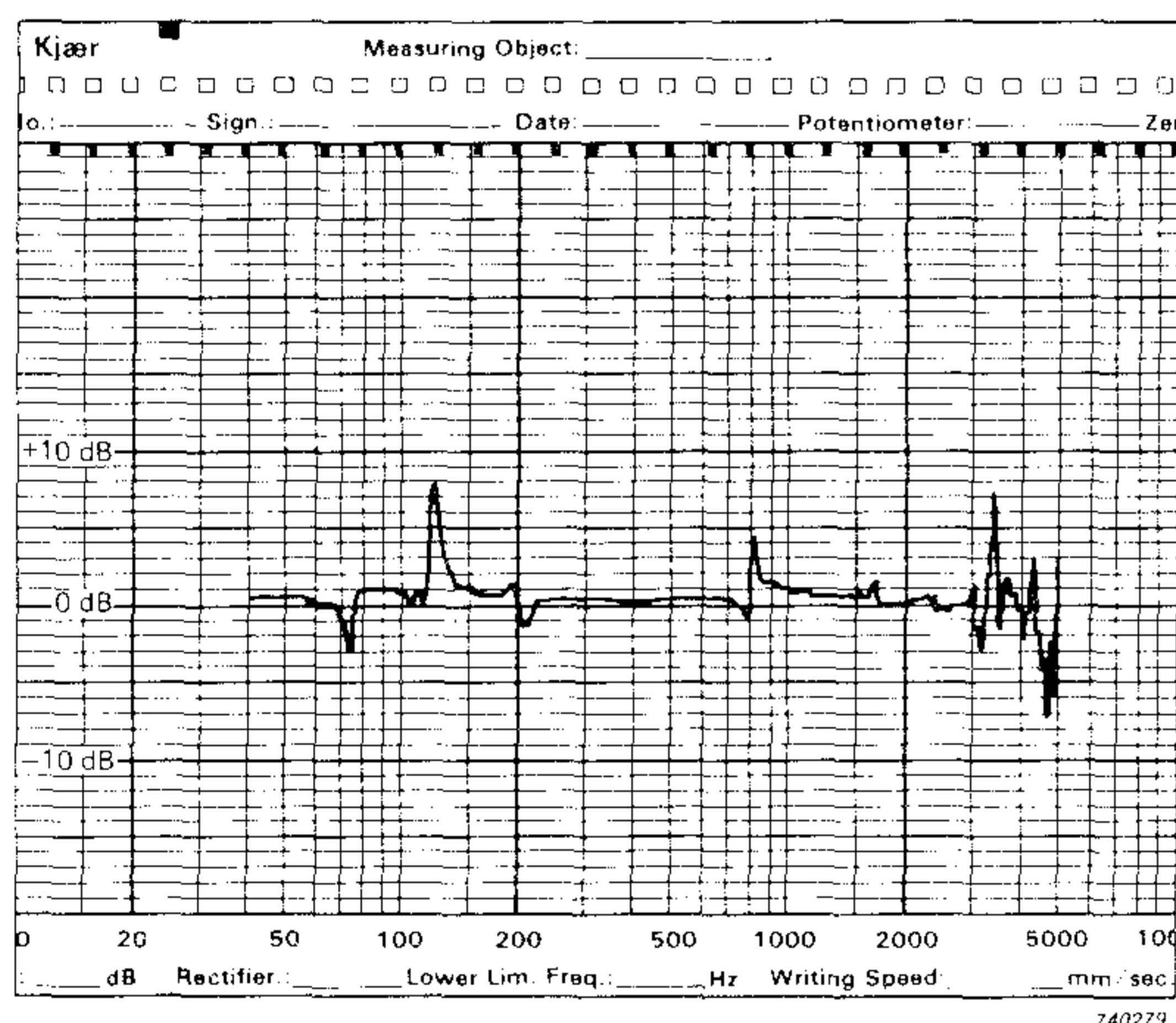
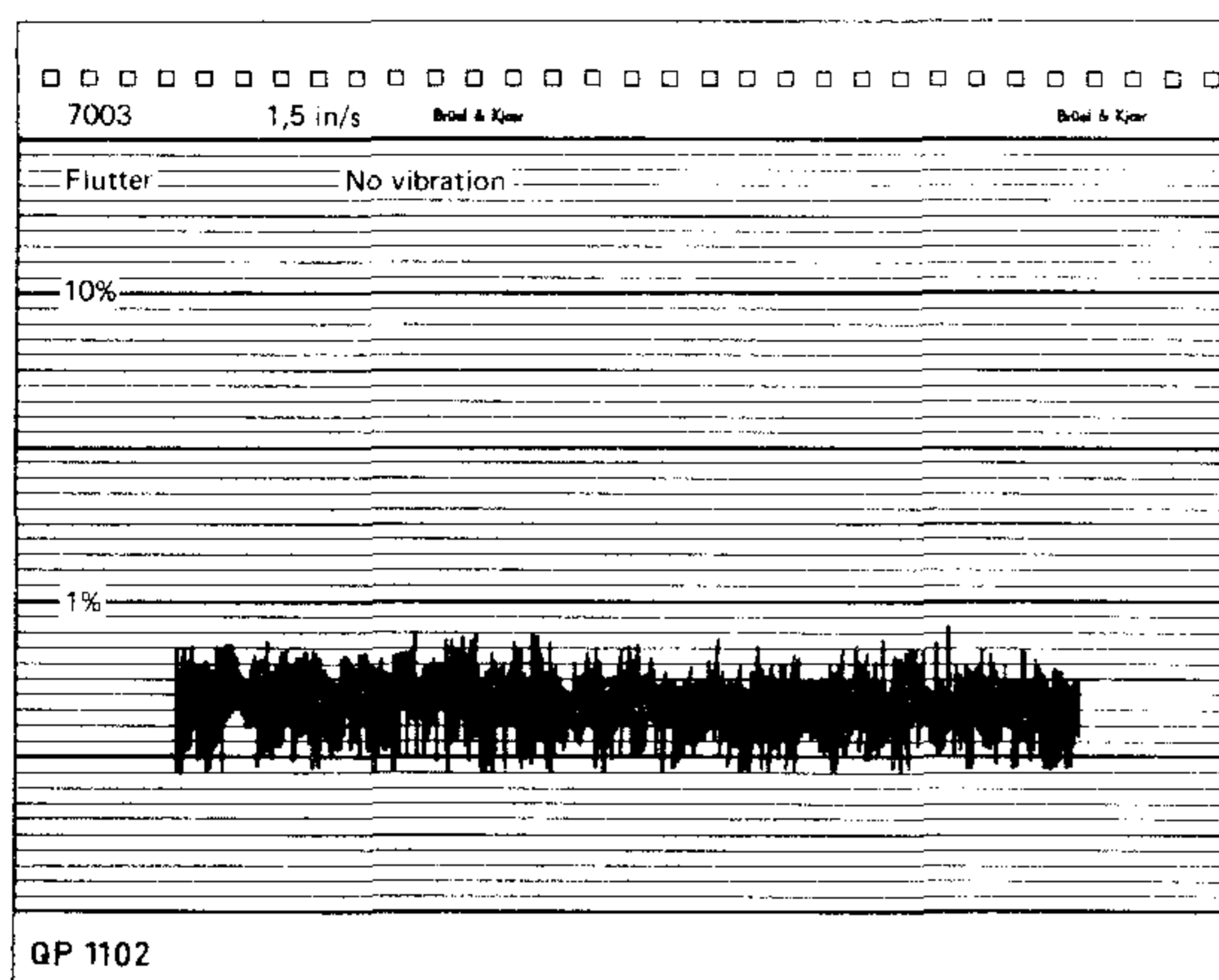

Fig.6. Measurement at a point diagonally across from the control accelerometer for constant acceleration corresponding to 16 rad/s^2
 a. Amplitude measurement
 b. Phase measurement relative to the control accelerometer

The measured results

The flutter level was first measured on the tape recorders without excitation running at 1,5 in/s and 15 in/s respectively. Figs.7a and 7b show the flutter levels for the Tape Recorder Type 7003 while Figs.7c and 7d show the corresponding flutter levels for the Tape Recorder Make X.



a

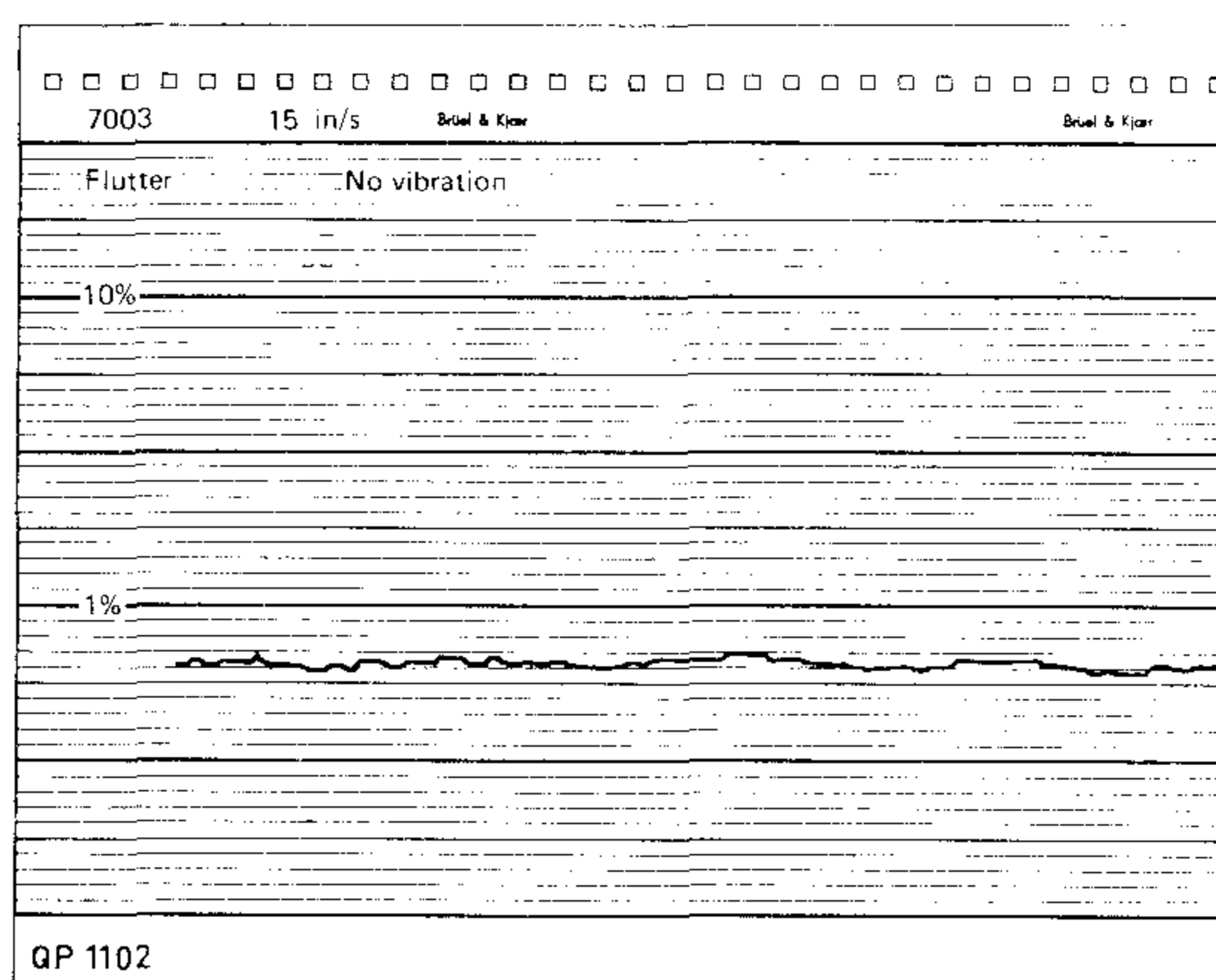

b

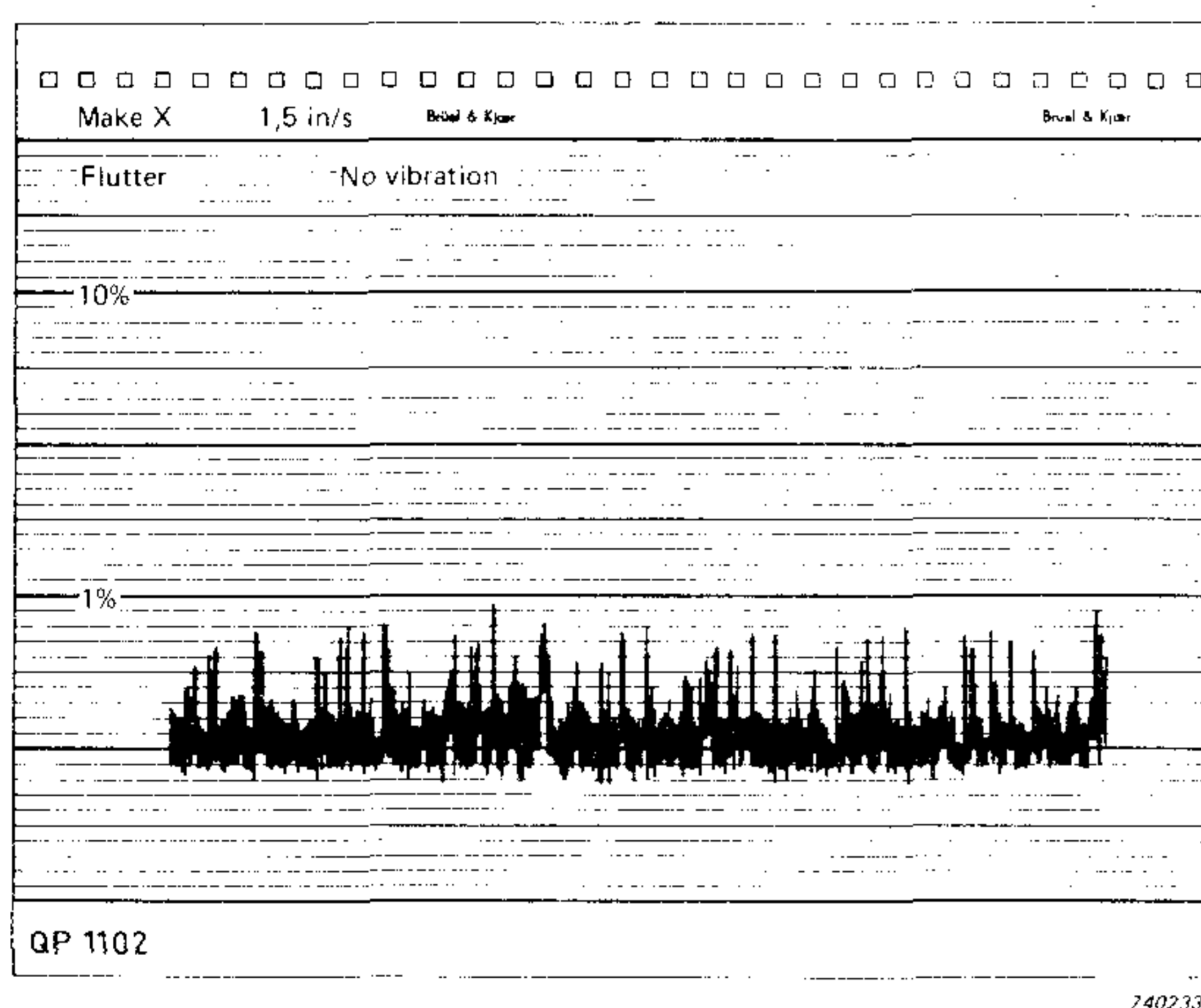

c

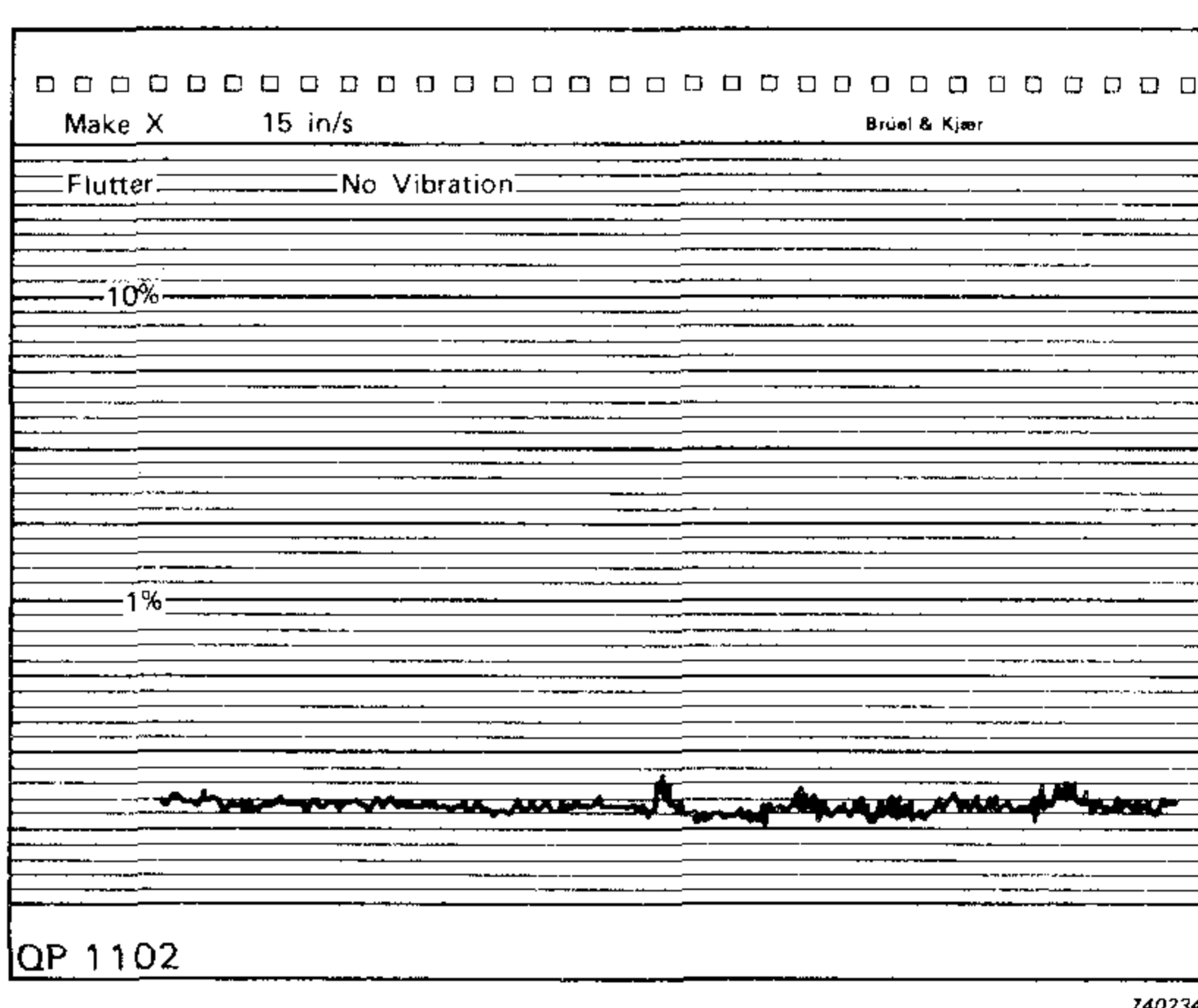

d

Fig.7. Flutter levels measured without excitation
 a. 7003 playing back at 1,5 in/s
 b. 7003 playing back at 15 in/s
 c. Make X playing back at 1,5 in/s
 d. Make X playing back at 15 in/s

It is seen that for 1,5 in/s the two tape recorders have approximately the same flutter level (0,6% to 0,7%). For 15 in/s the 7003 has approximately 0,6% while the Tape Recorder Make X has an extremely low level (approximately 0,25%). The difference in pen deflection between the results for 1,5 in/s and 15 in/s is due to the use of different (10% and 1%) ranges of the flutter meter.

Figs.8a to 8d show the flutter levels of the 7003 when vibrated in the X, Y and Z directions and with different vibration levels and Figs.9a to

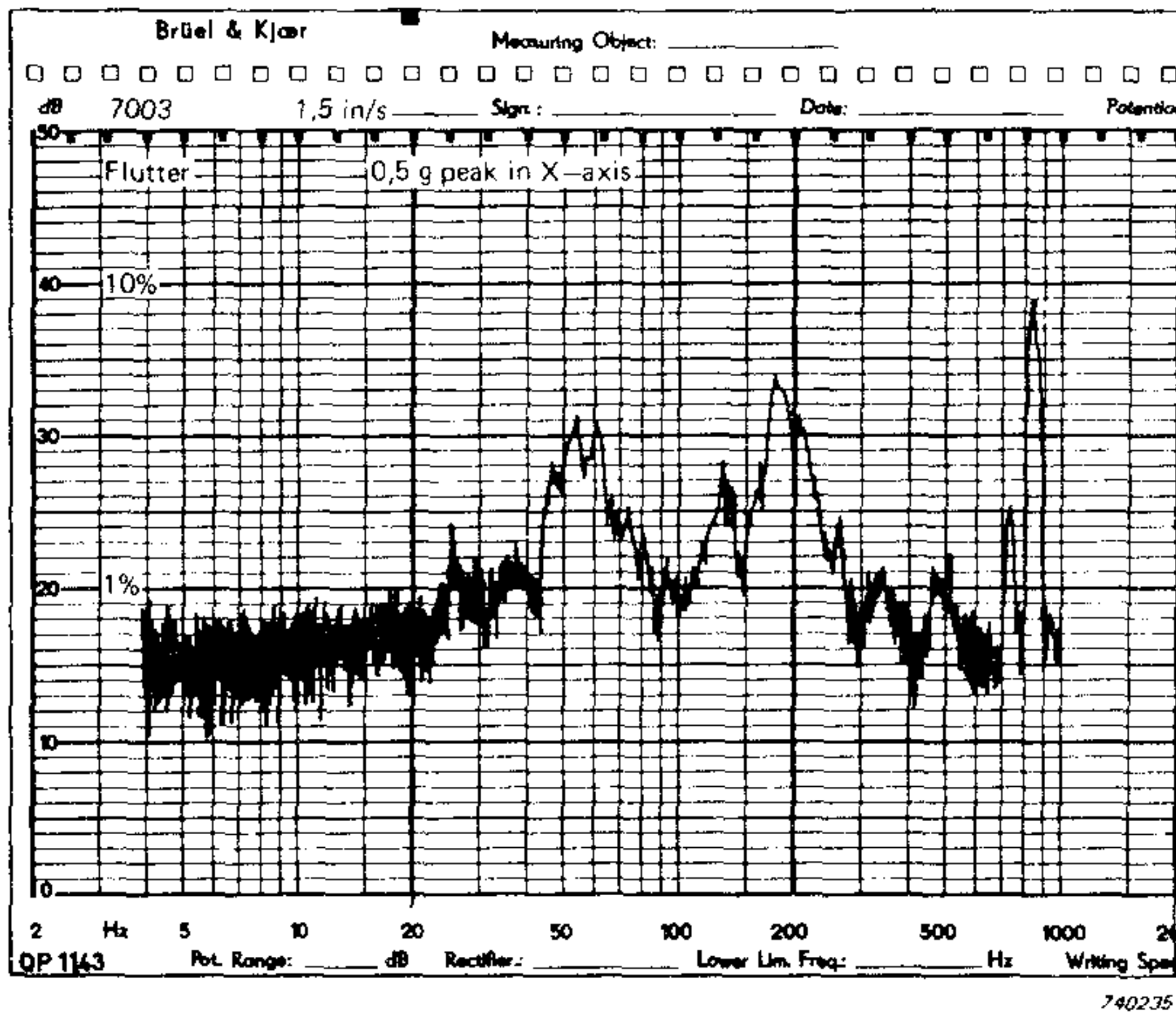

a

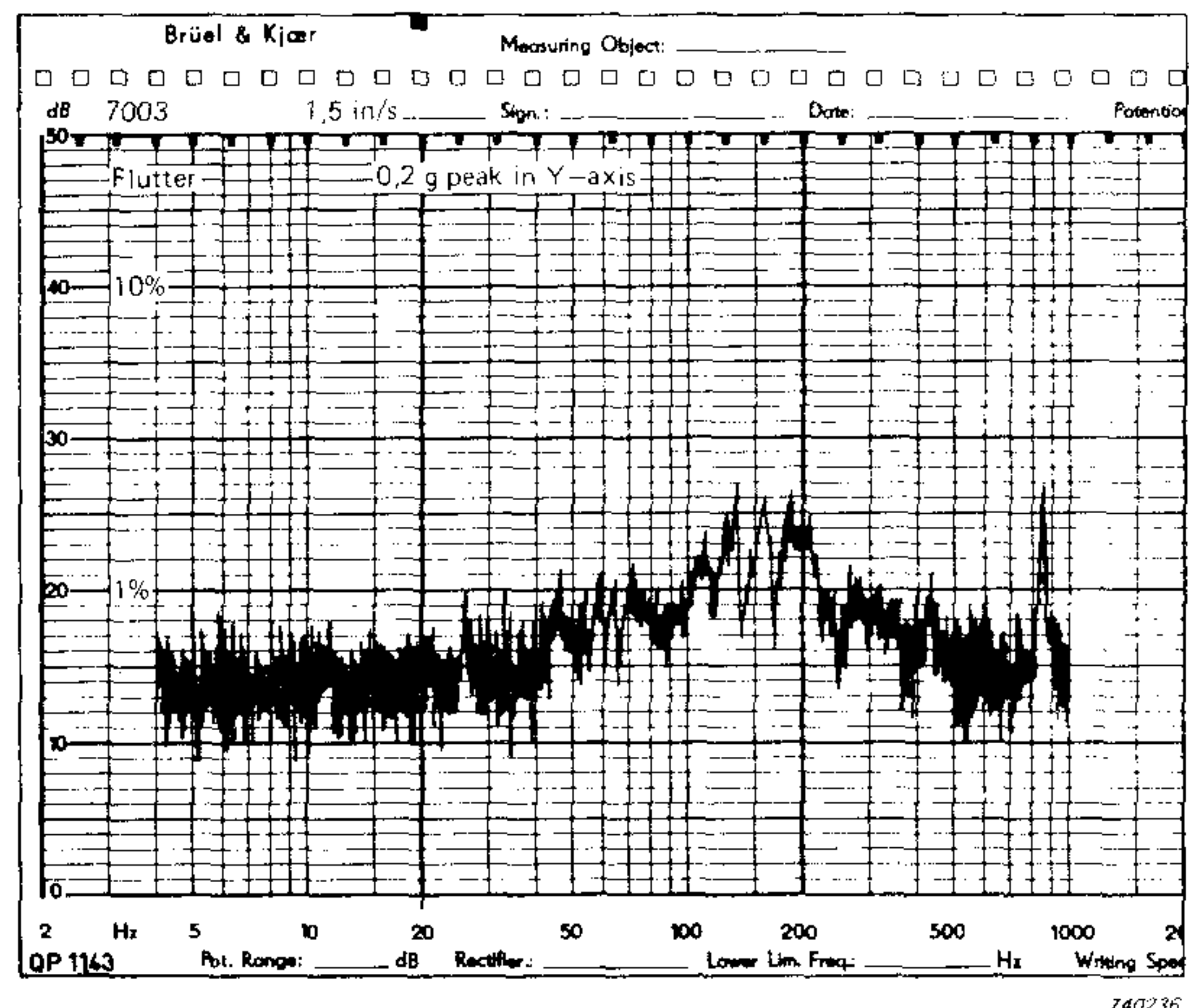

b

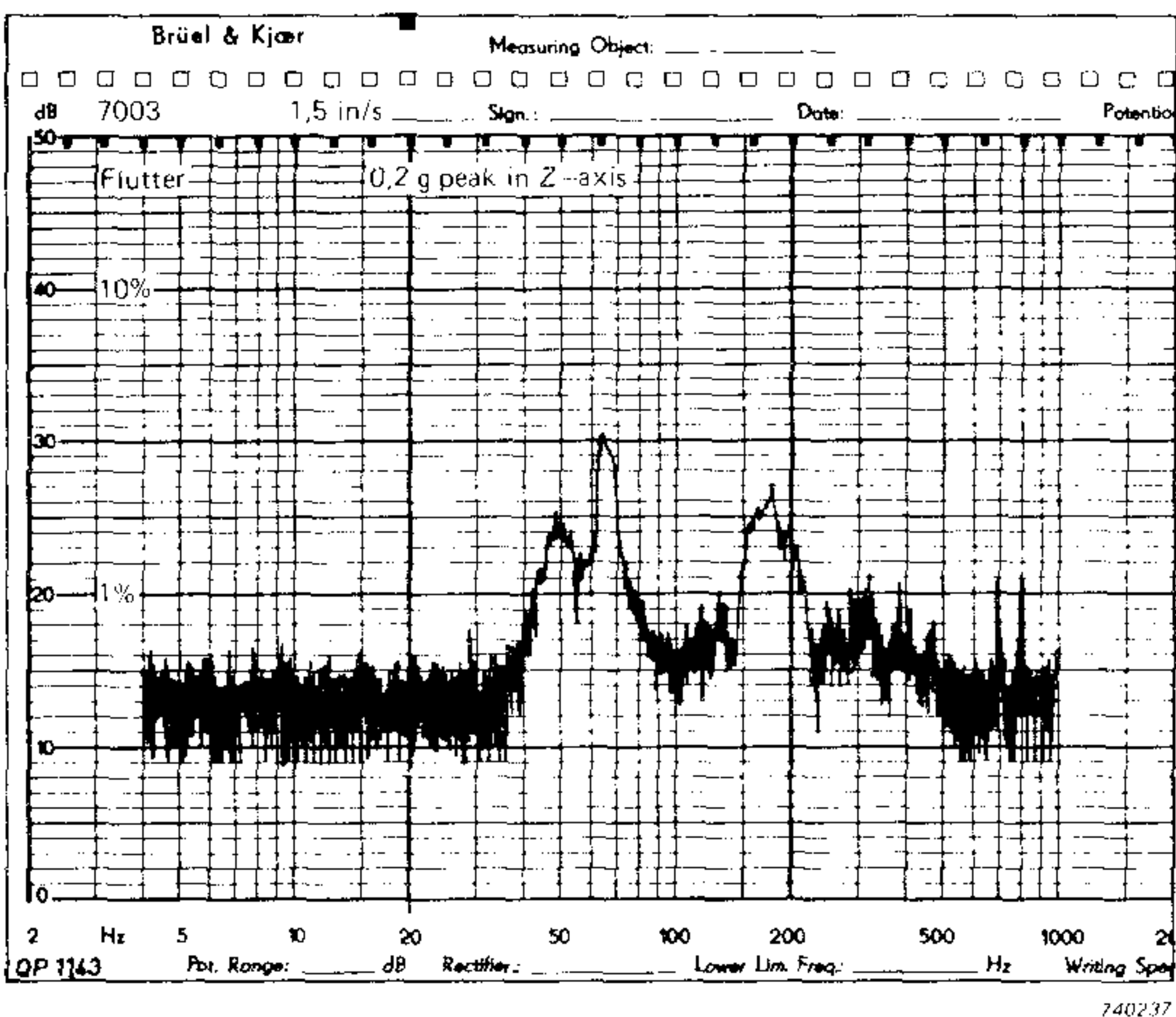

c

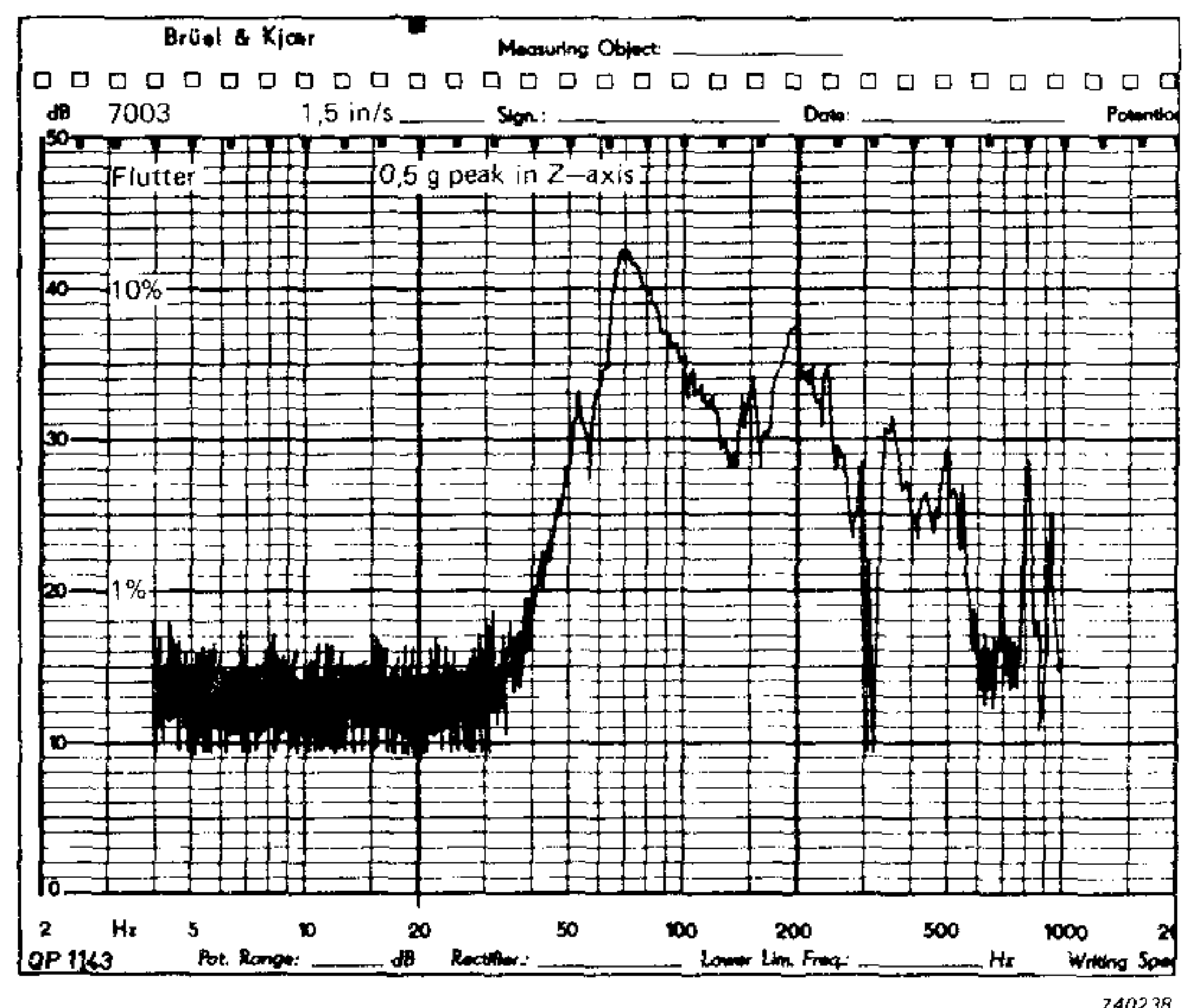

d

Fig. 8. Flutter levels of Tape Recorder Type 7003 playing back at 1,5 in/s
 a. 0,5 g peak in the X axis
 b. 0,2 g peak in the Y axis
 c. 0,2 g peak in the Z axis
 d. 0,5 g peak in the Z axis

9c show the corresponding flutter levels for the Tape Recorder Make X due to vibration levels of 0,2 g peak in the three axes.

In Figs. 10a to 10c are given the flutter curves for rotational vibration of the Tape Recorders Type 7003 and Make X, both operating at 1,5 in/s.

When operating at 15 in/s both tape recorders show substantially better flutter characteristics under vibration. Figs. 11a to 11e display the re-

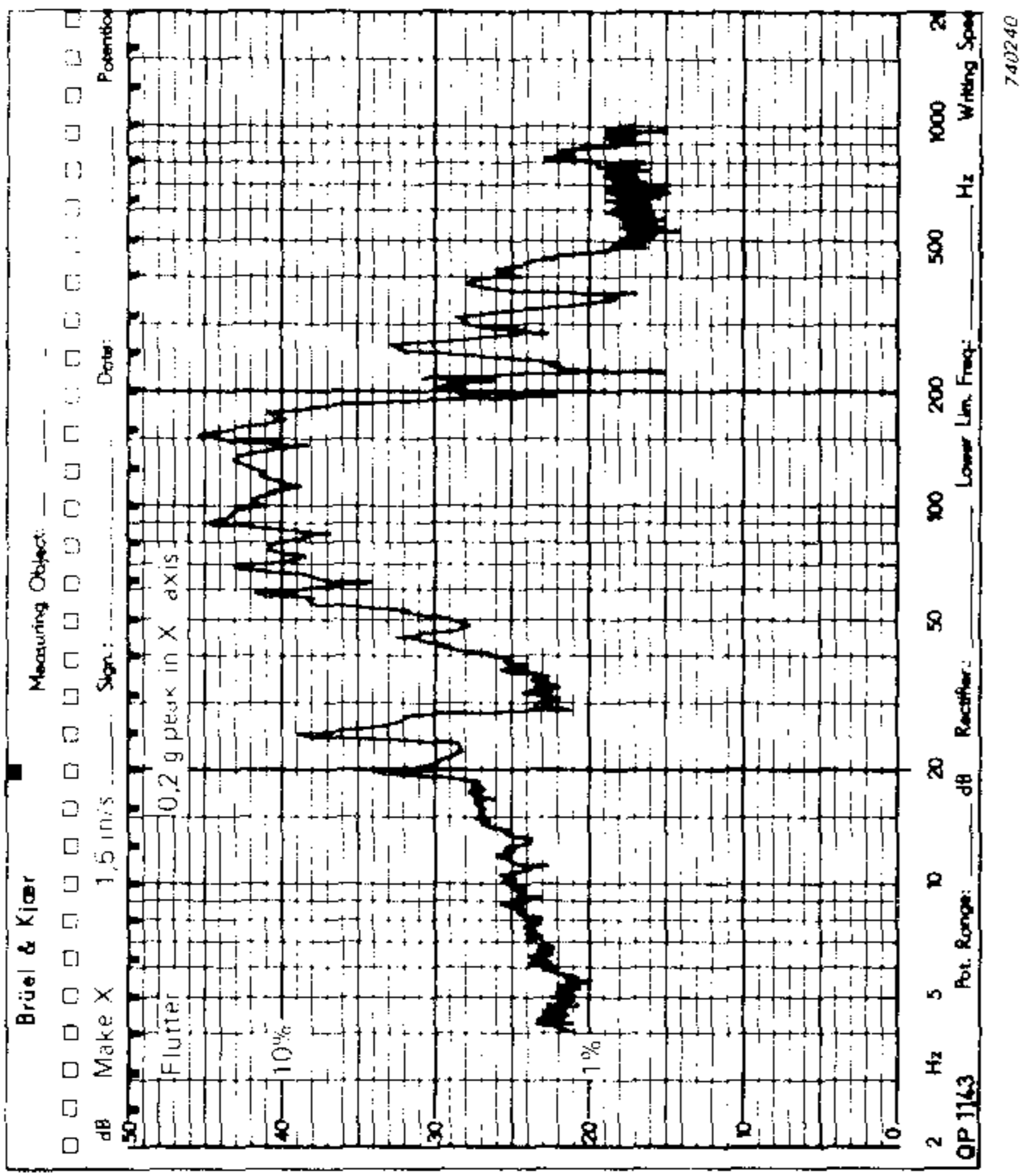

a. 0.2 g peak in the X axis

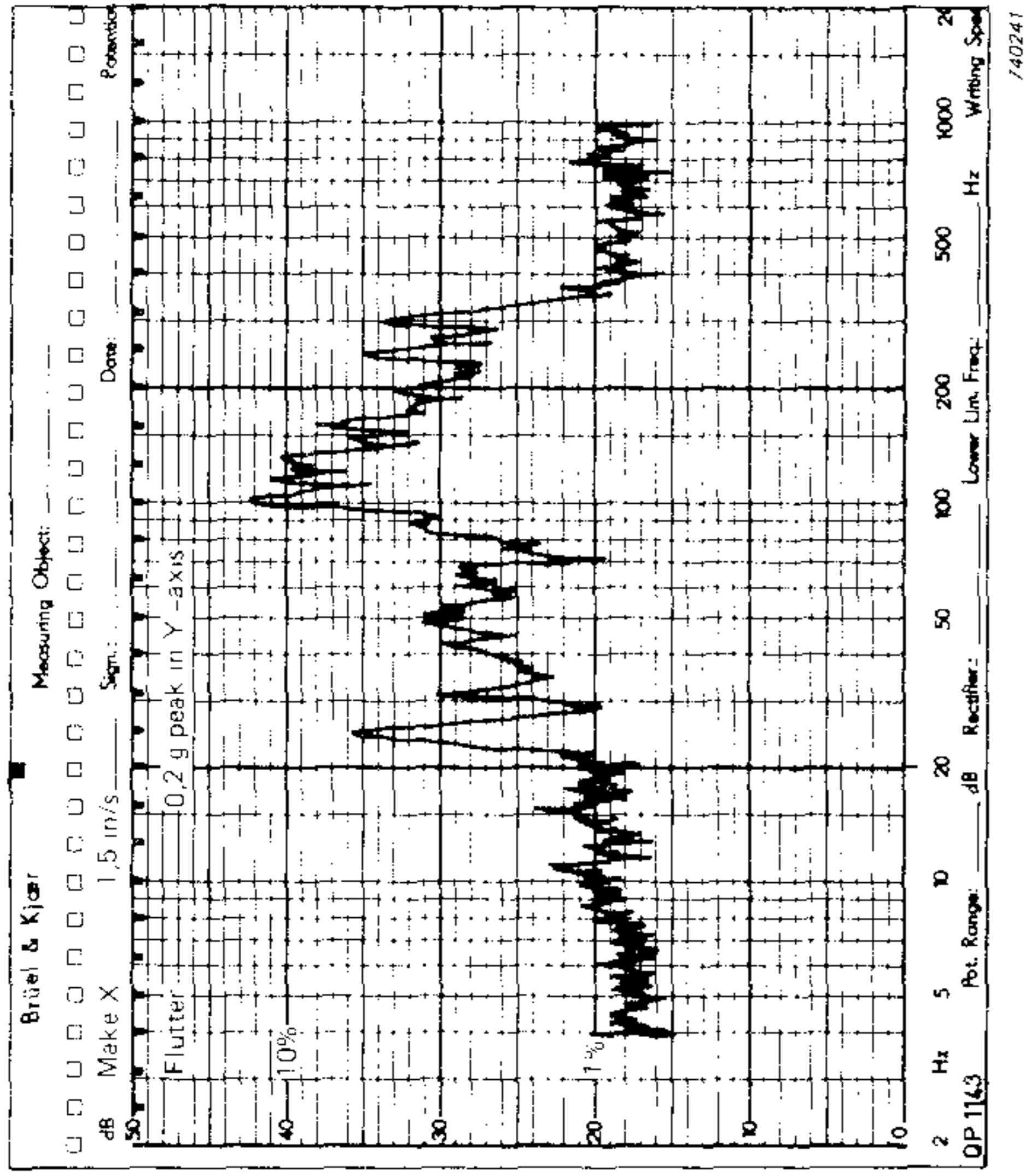

b. 0.2 g peak in the Y axis

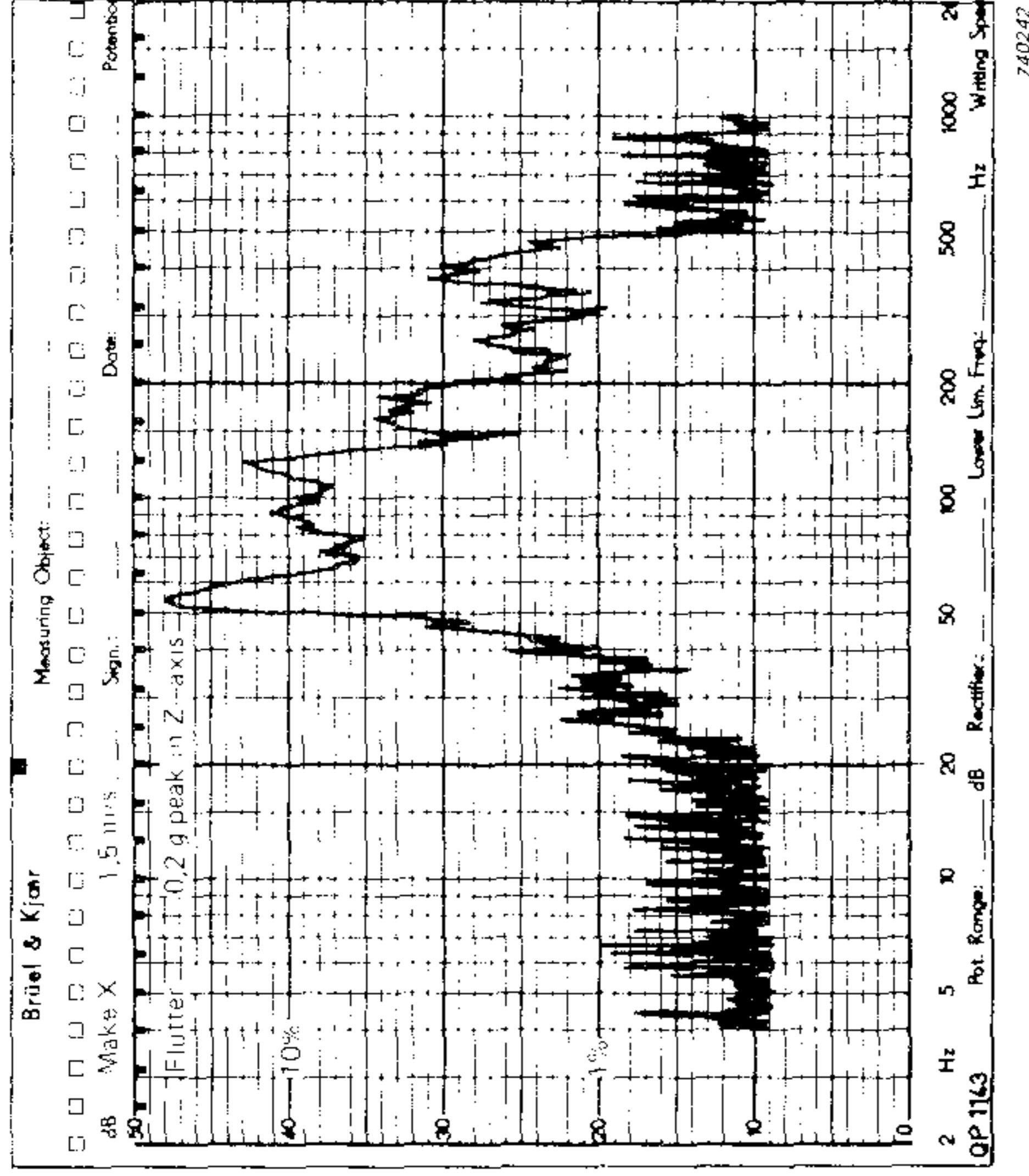

c. 0.2 g peak in the Z axis

Fig. 9. Flutter levels of Tape Recorder Make X playing back at 1,5 in/s

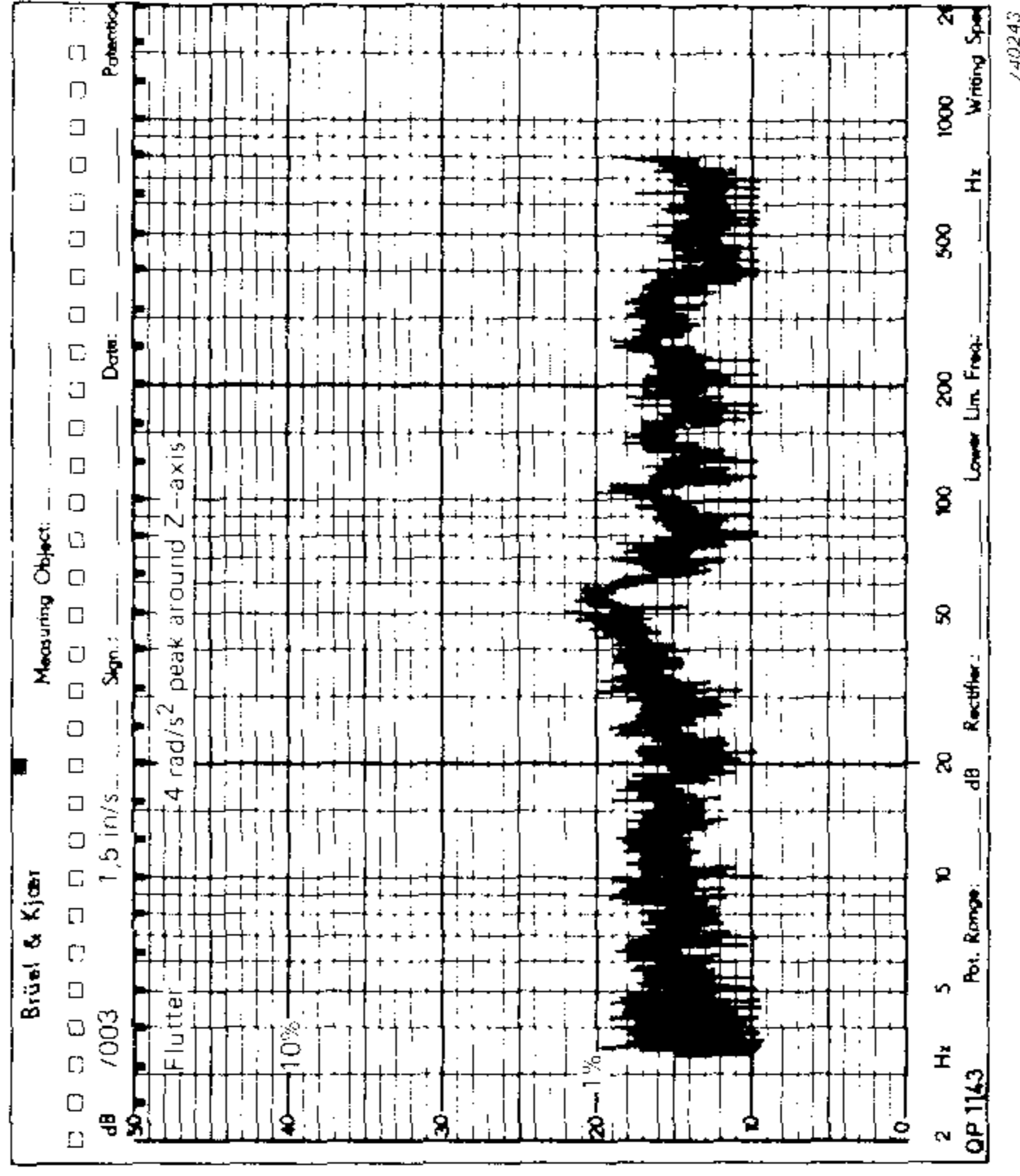

a. 4 rad/s² peak on 7003

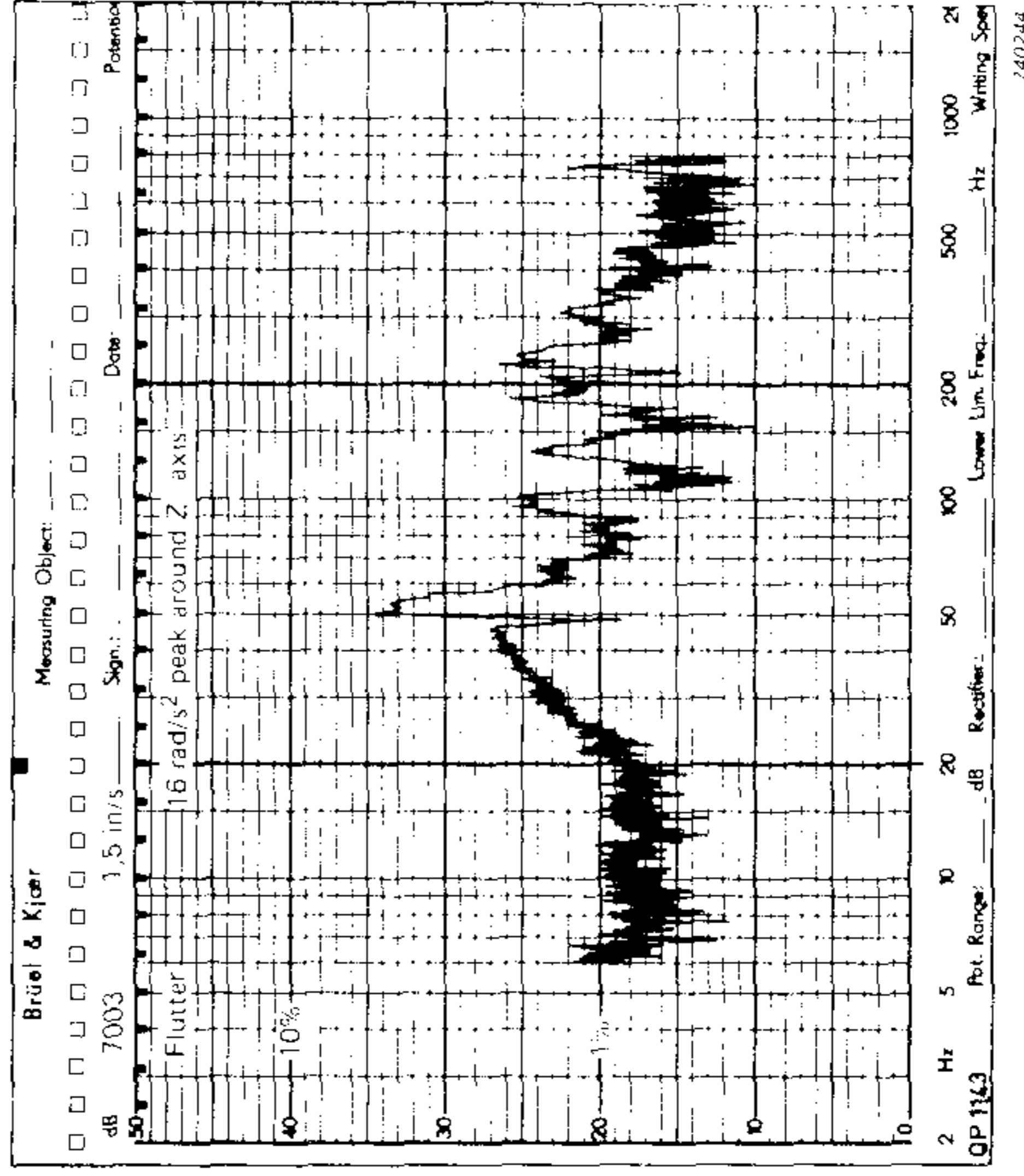

b. 16 rad/s² peak on 7003

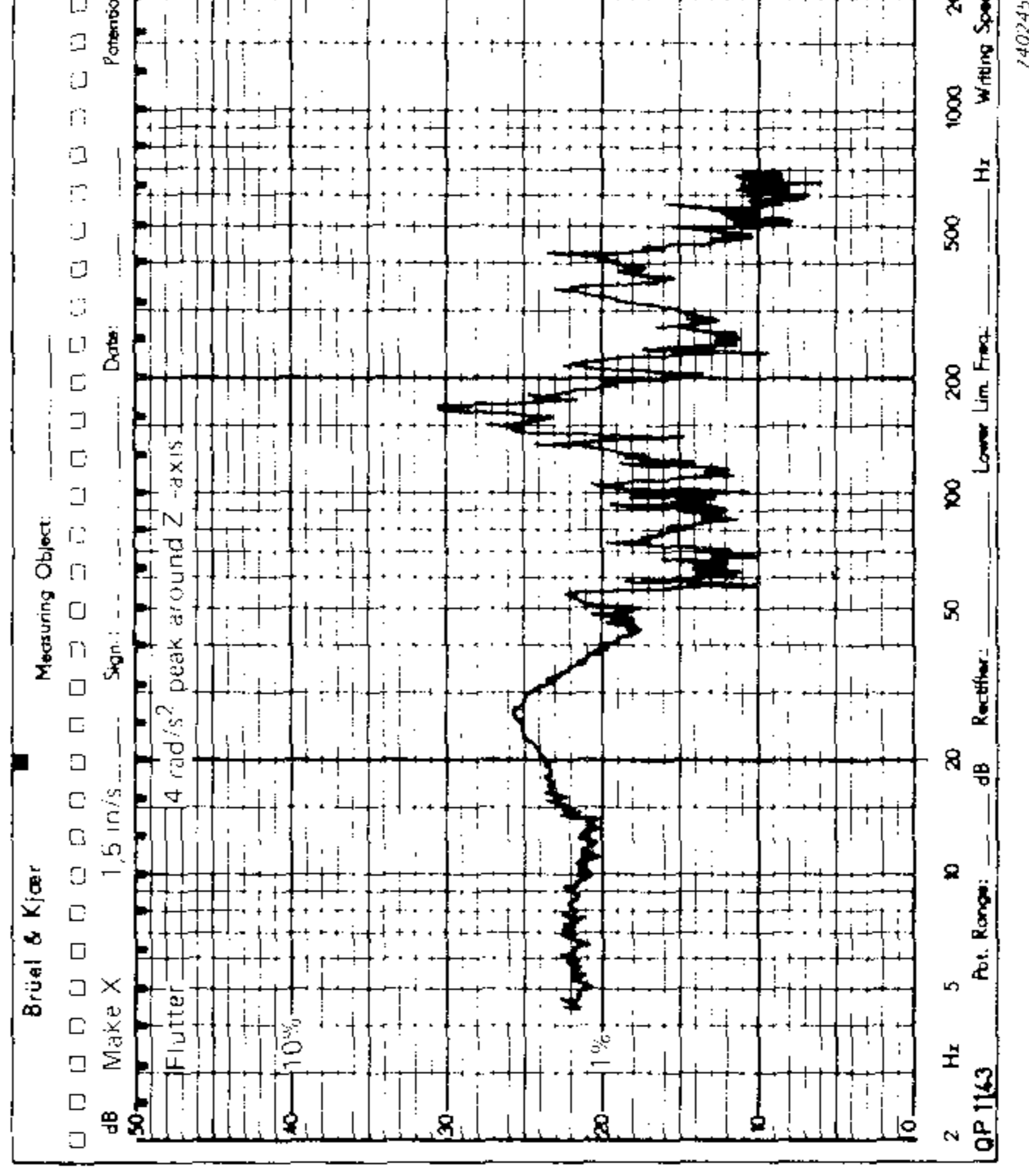

c. 4 rad/s² peak on Make X

Fig. 10. Flutter curves for rotational vibration for the two tape recorders playing back at 1,5 in/s

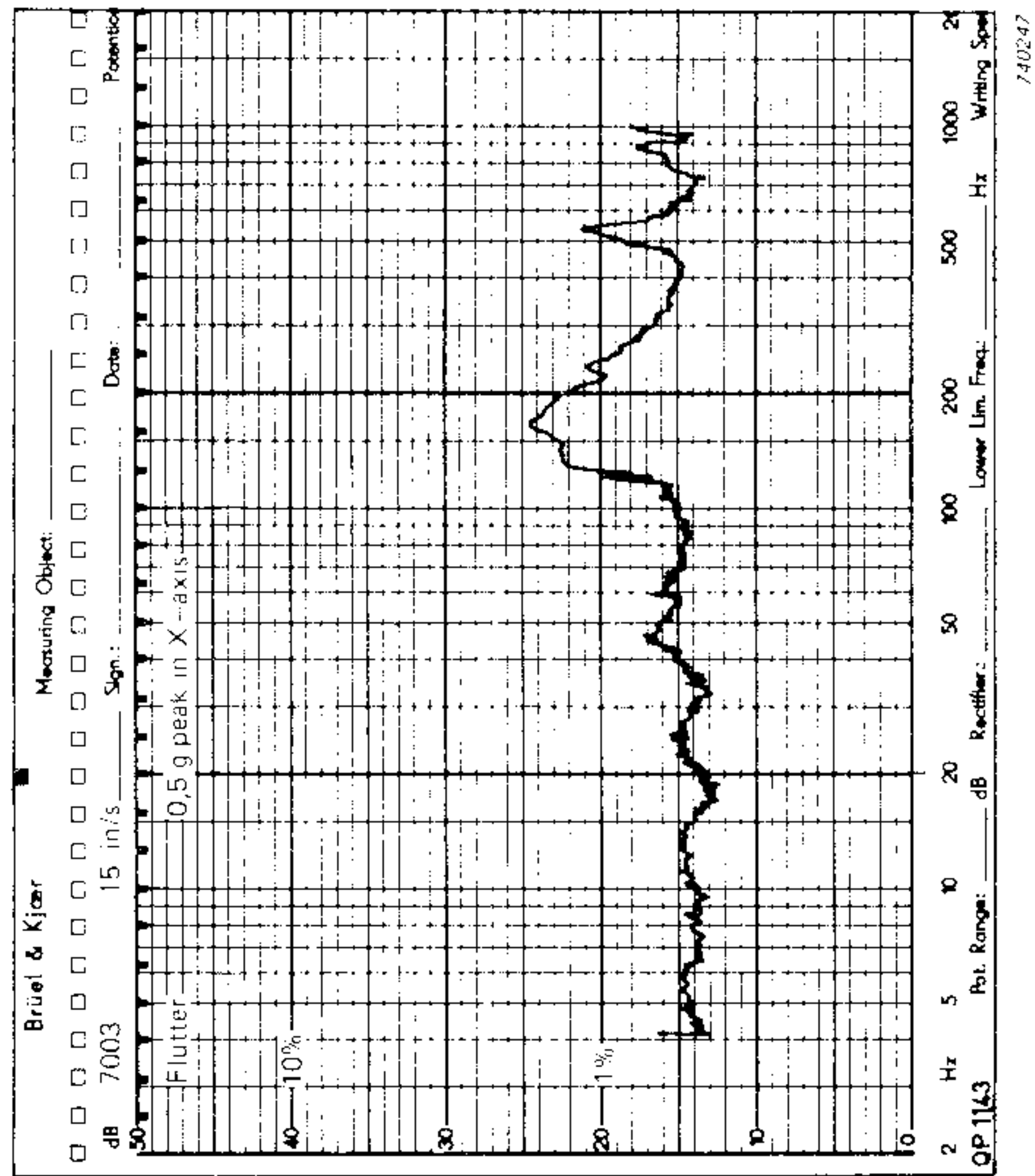

a

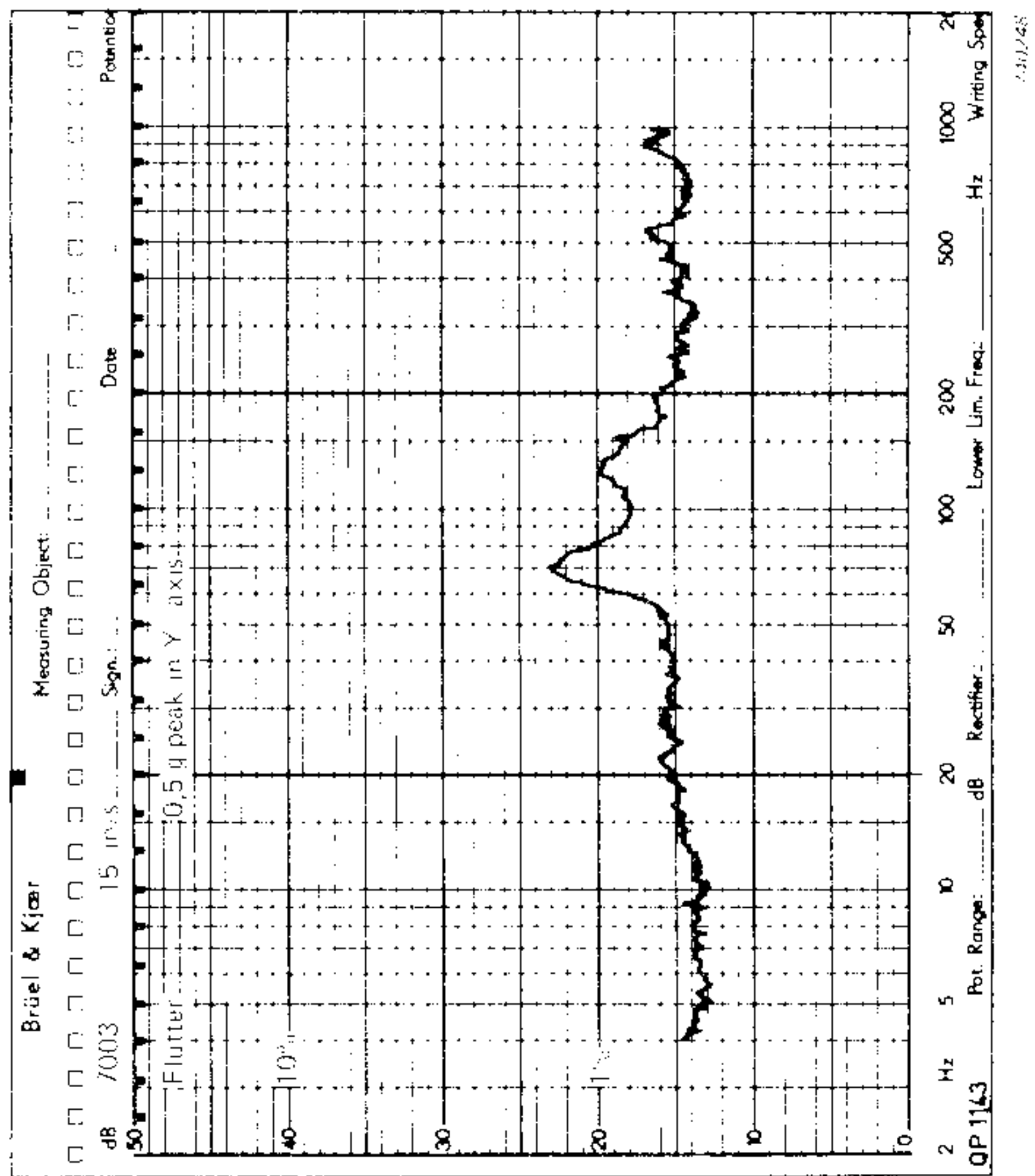

b

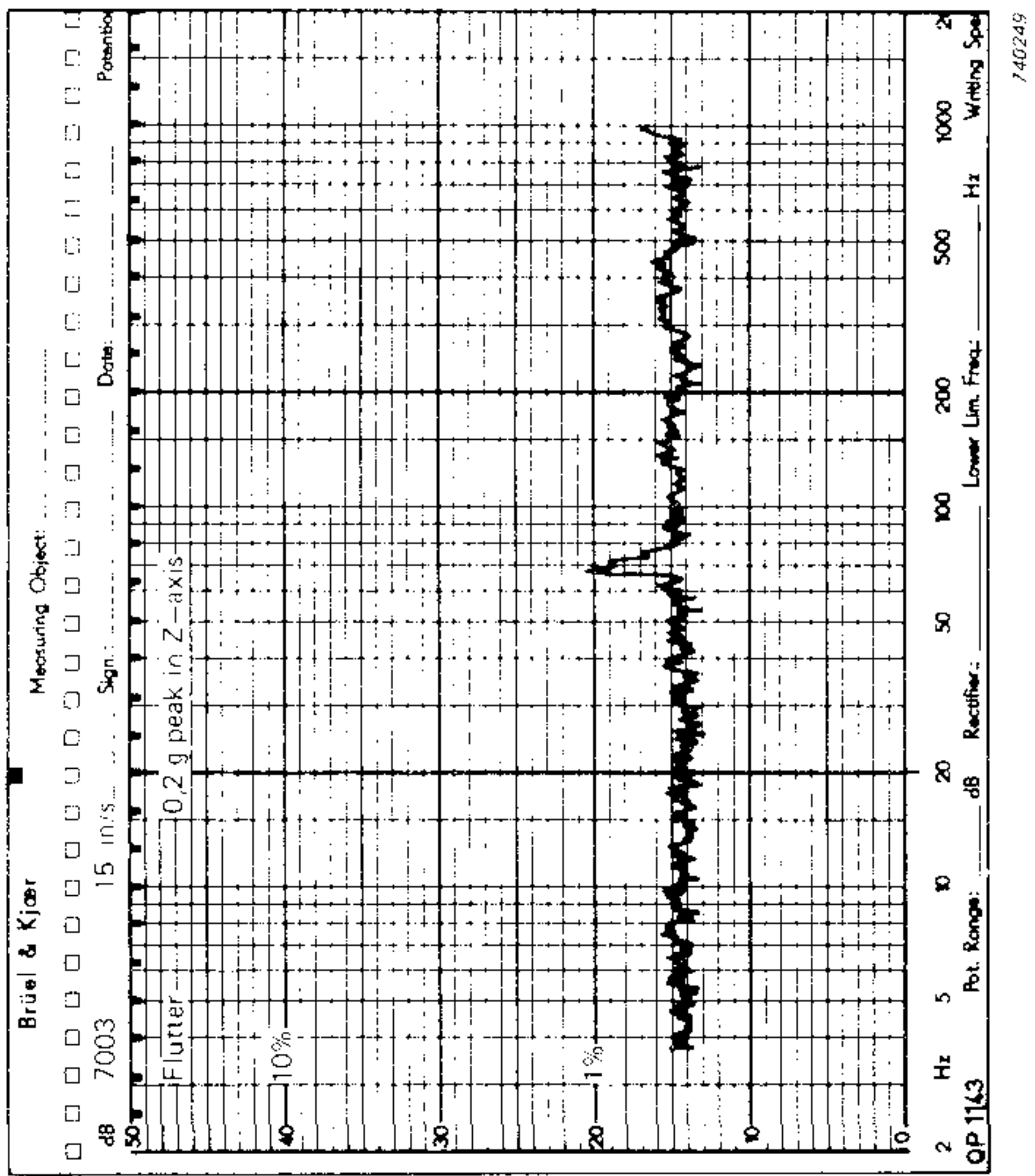

c

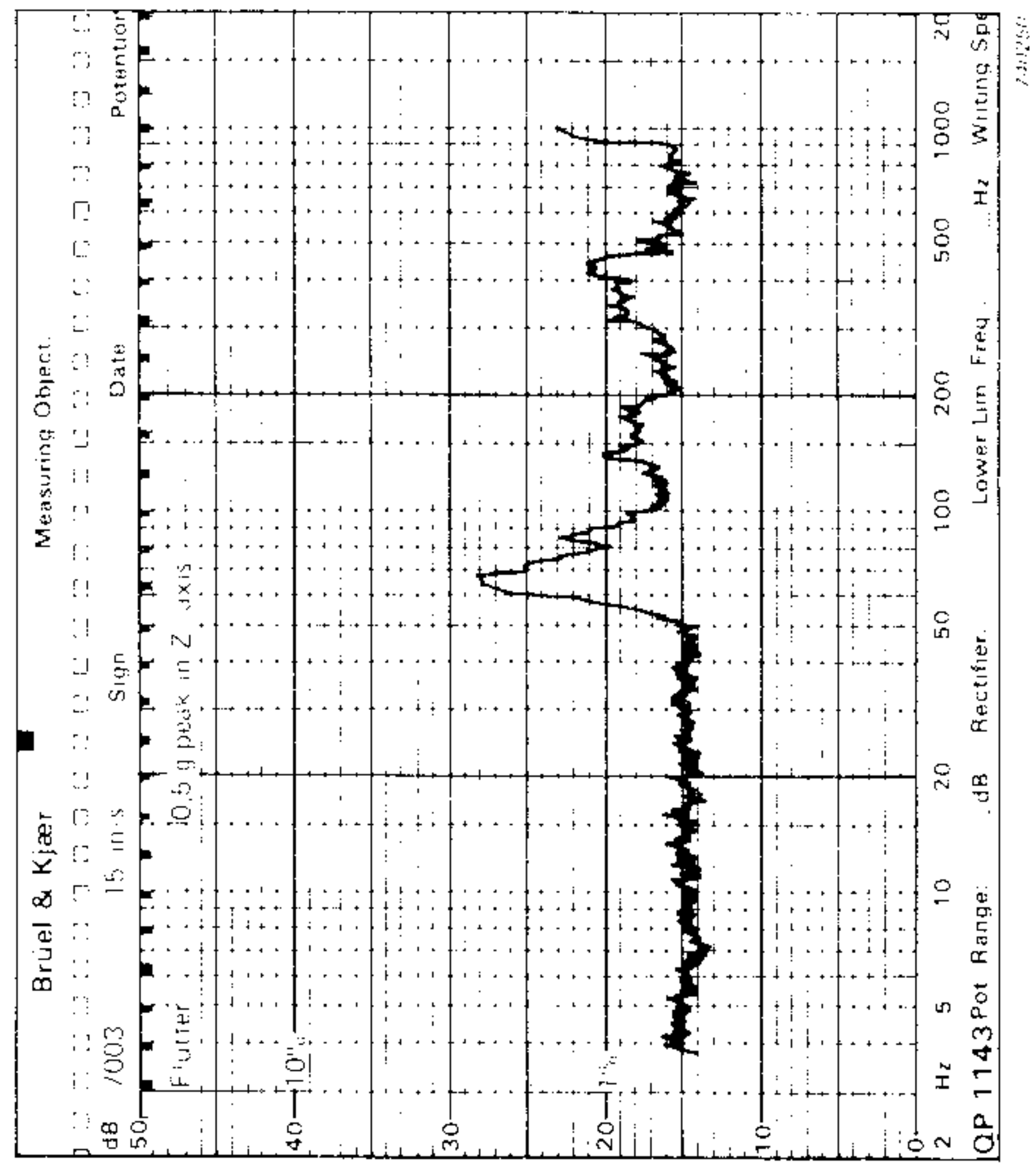

d

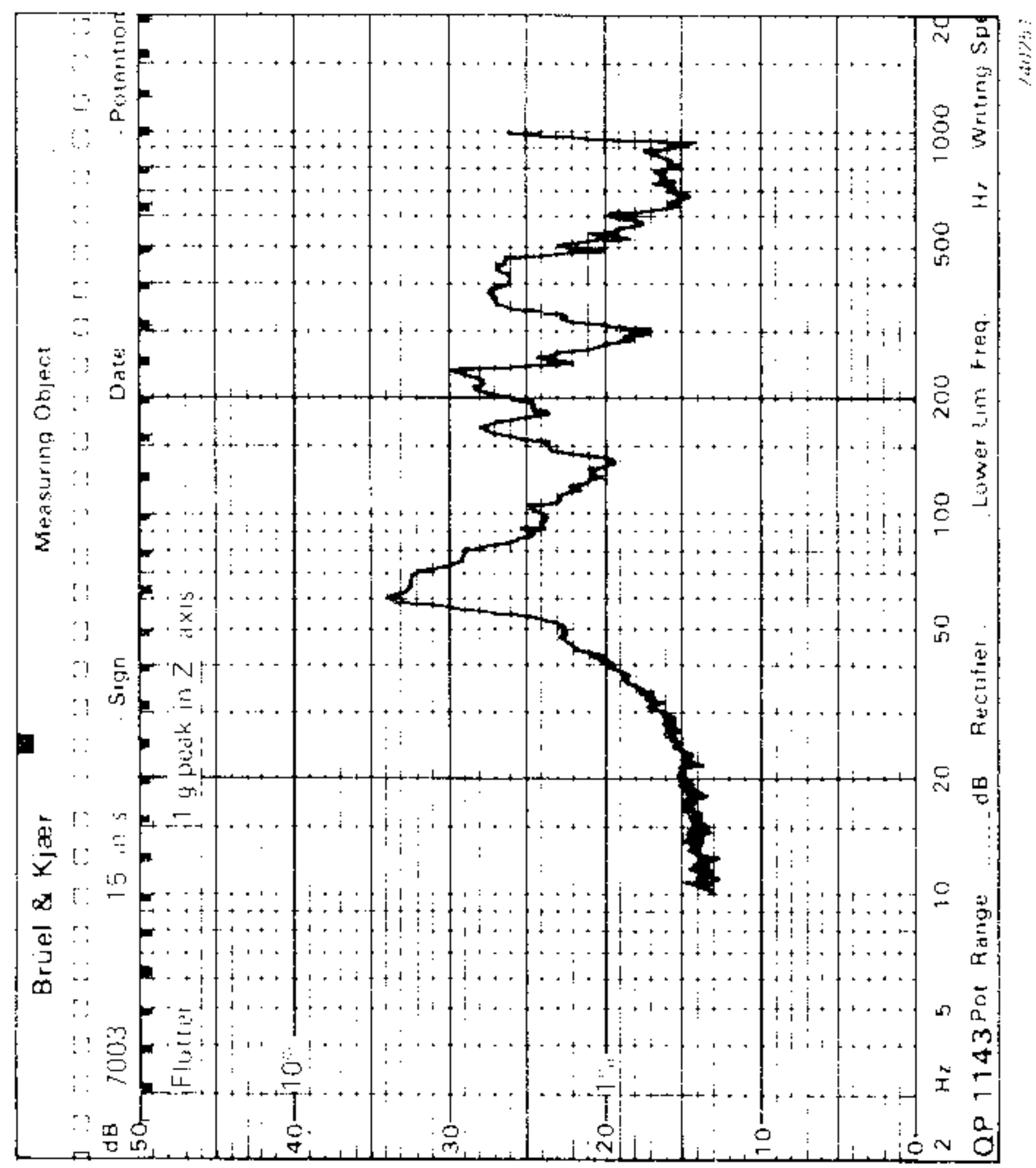

e

Fig. 11. Flutter levels of Tape Recorder Type 7003 playing back at 15 in/s

- 0.5 g peak in the X axis
- 0.5 g peak in the Y axis
- 0.2 g peak in the Z axis
- 0.5 g peak in the Z axis
- 1 g peak in the Z axis

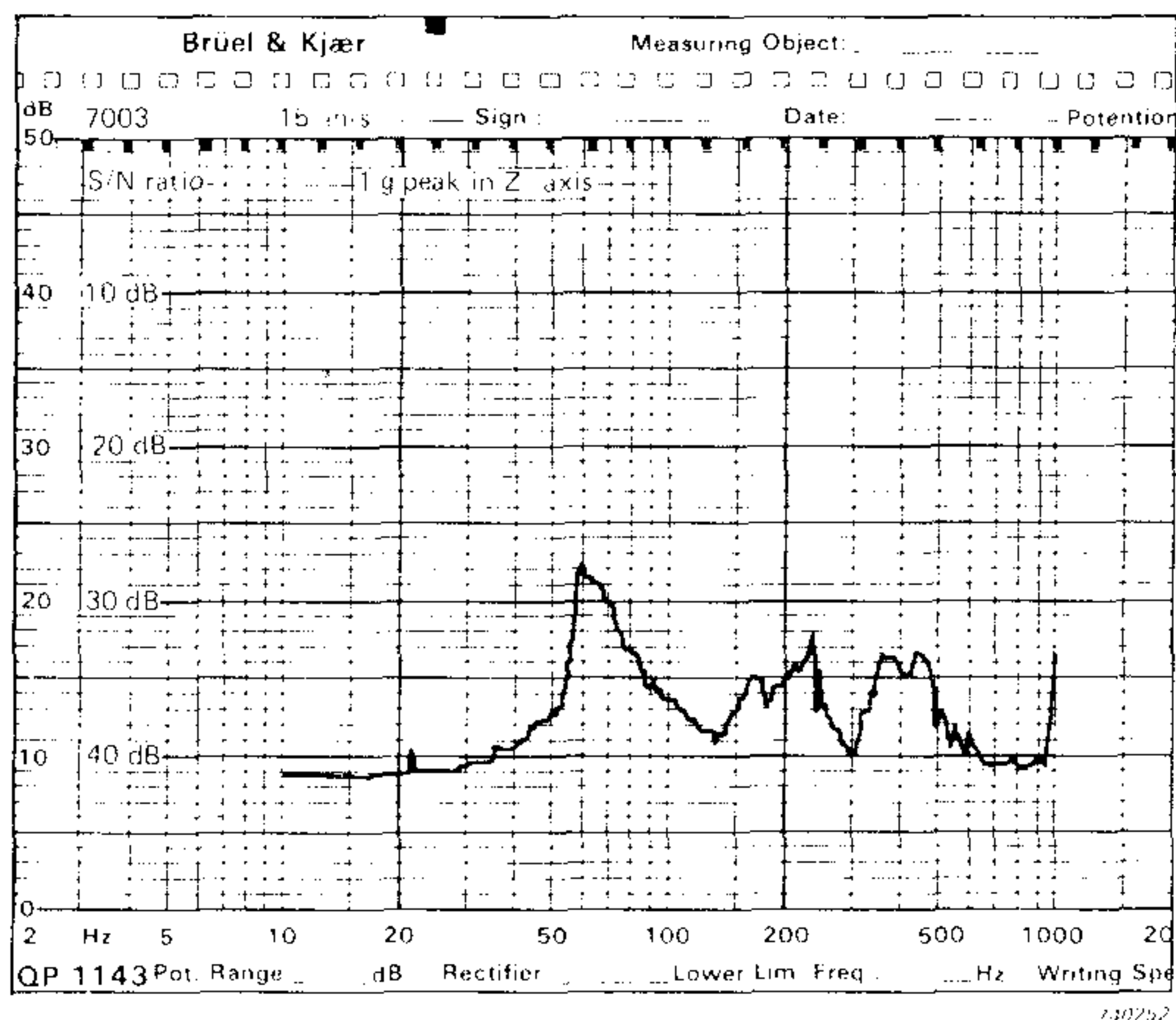
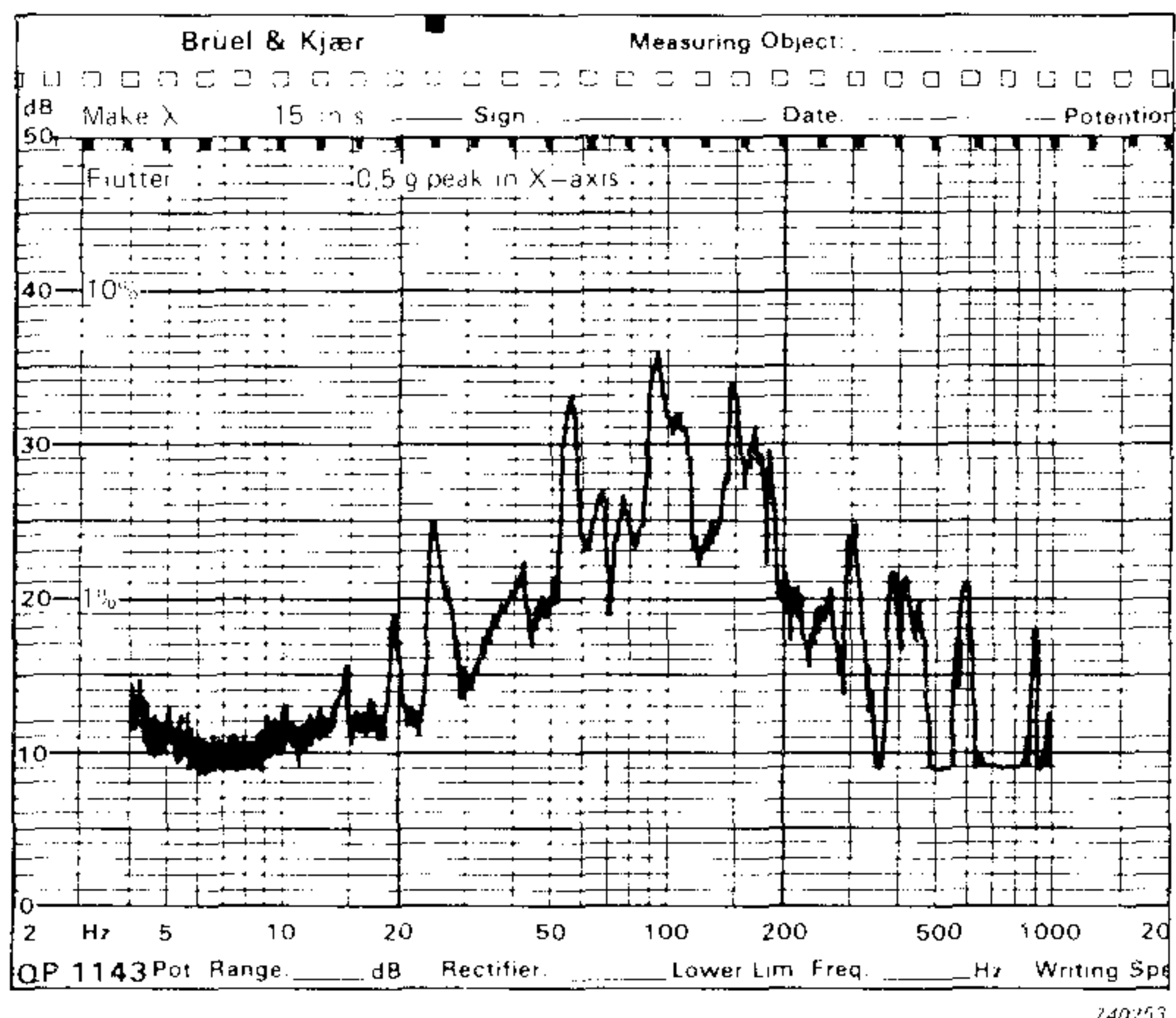
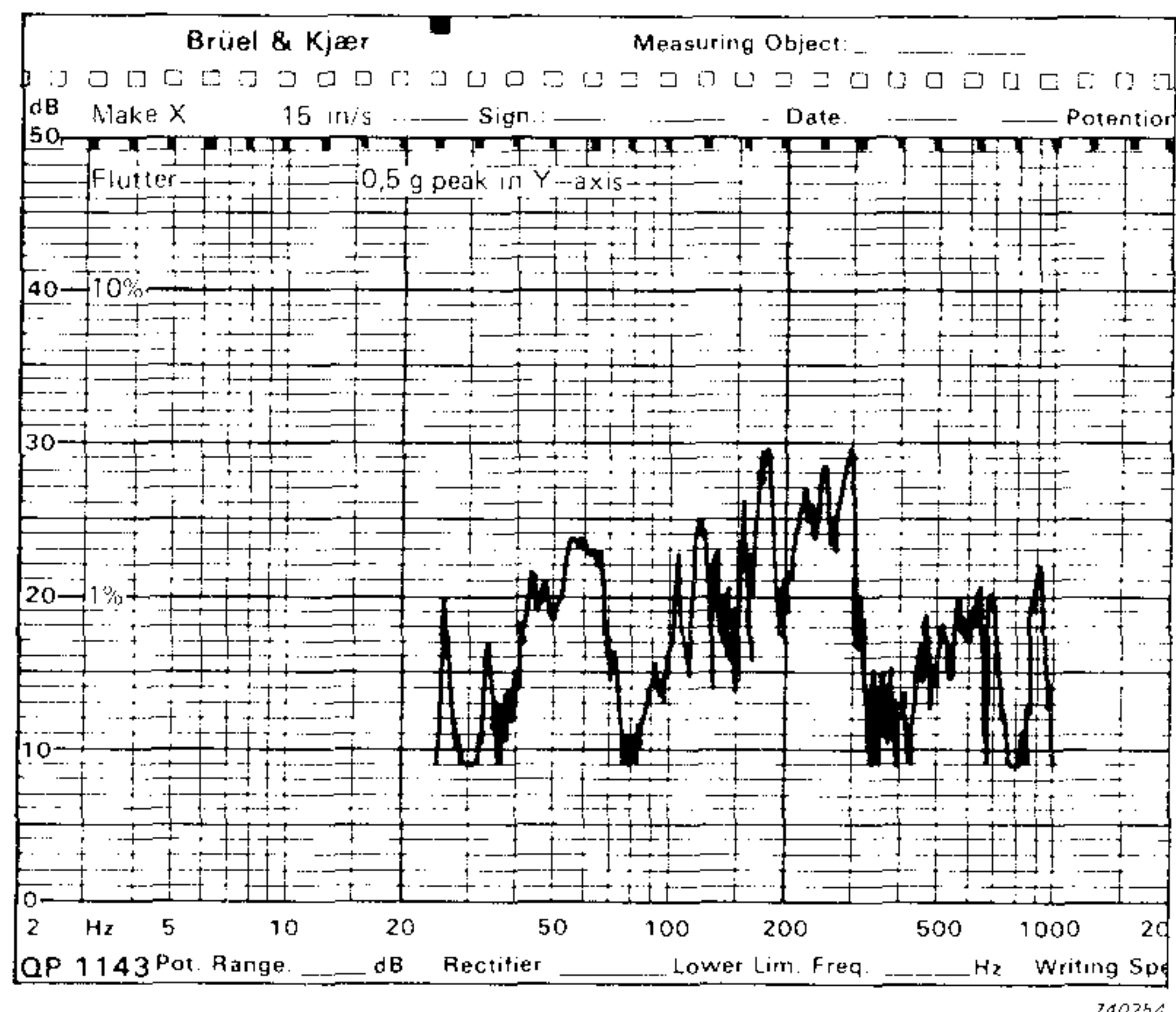

Fig.12. The broadband signal-to-noise ratio of 7003 measured under the same conditions as Fig.11



a



b

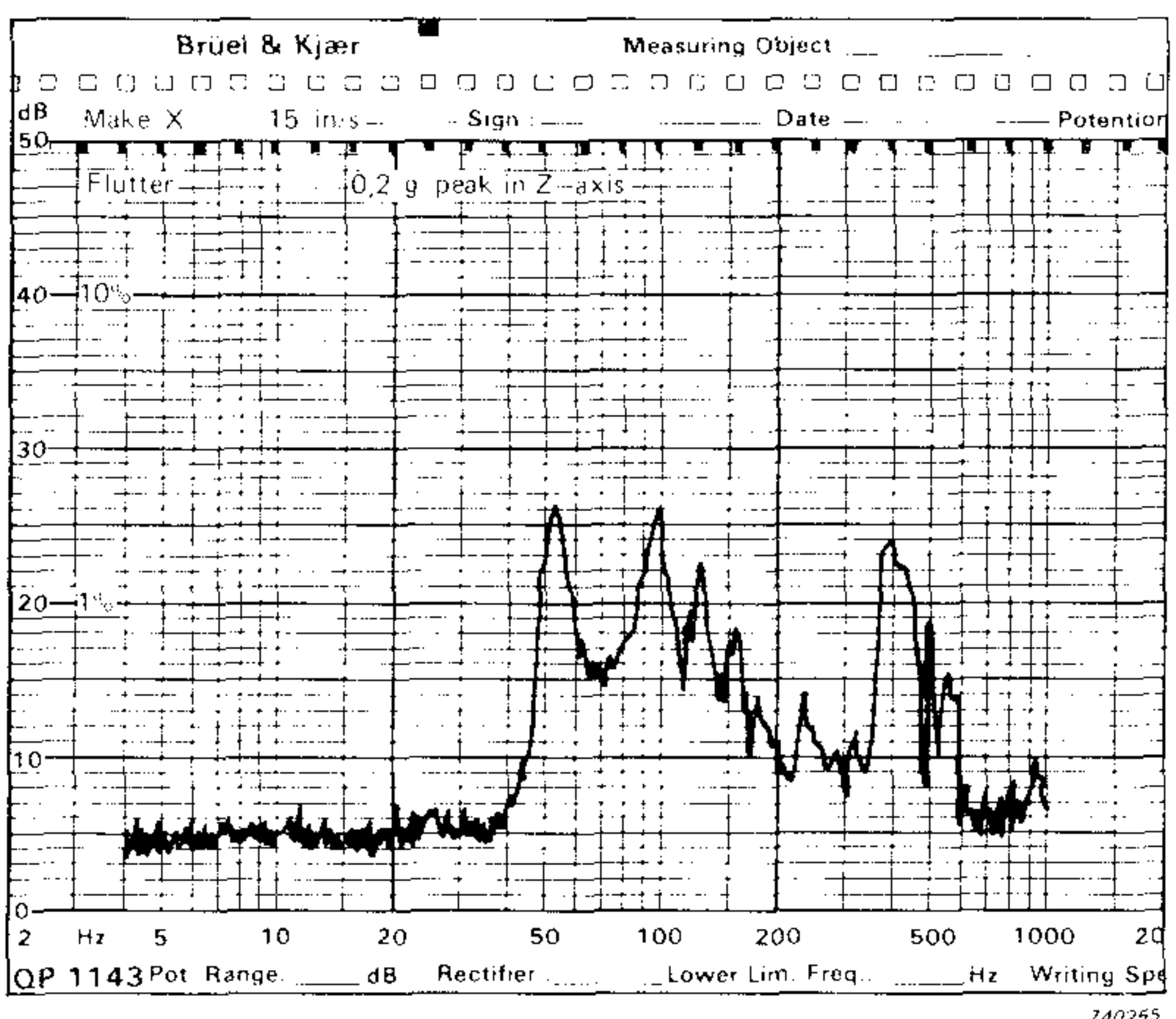

c

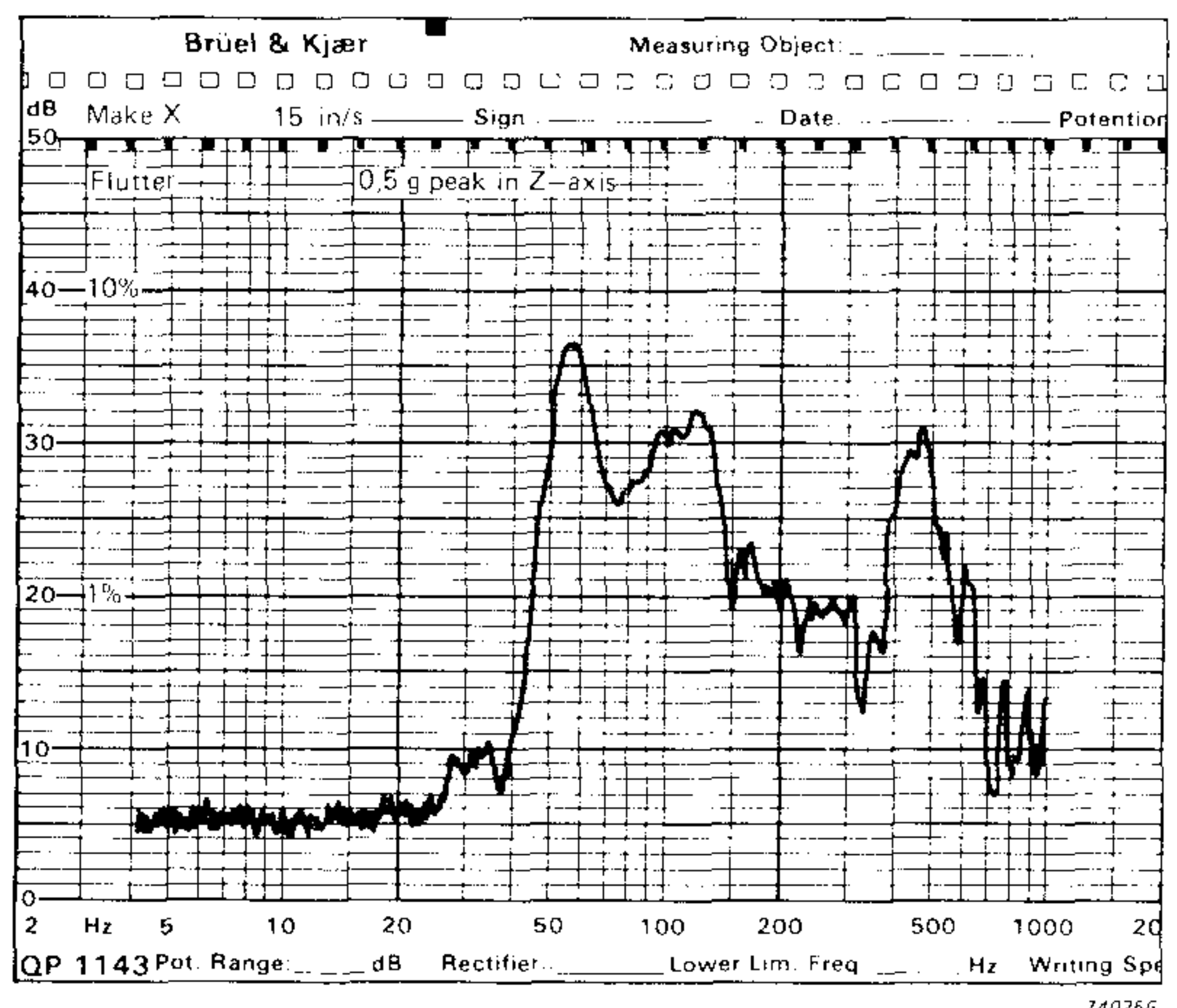

d

Fig.13. Flutter levels of Tape Recorder Make X playing back at 15 in/s
 a. 0,5 g peak in the X axis
 b. 0,5 g peak in the Y axis
 c. 0,2 g peak in the Z axis
 d. 0,5 g peak in the Z axis

sults obtained for vibration in the three axes with Tape Recorder Type 7003, and for further understanding of the vibration effect the resulting broadband signal to noise ratio is given in Fig.12. In Figs.13a to 13d the flutter levels for Tape Recorder Make X are given for vibration in the three axes.

Finally, the response to rotational vibration at 15 in/s is given for the two tape recorders in Figs.14a to 14c.

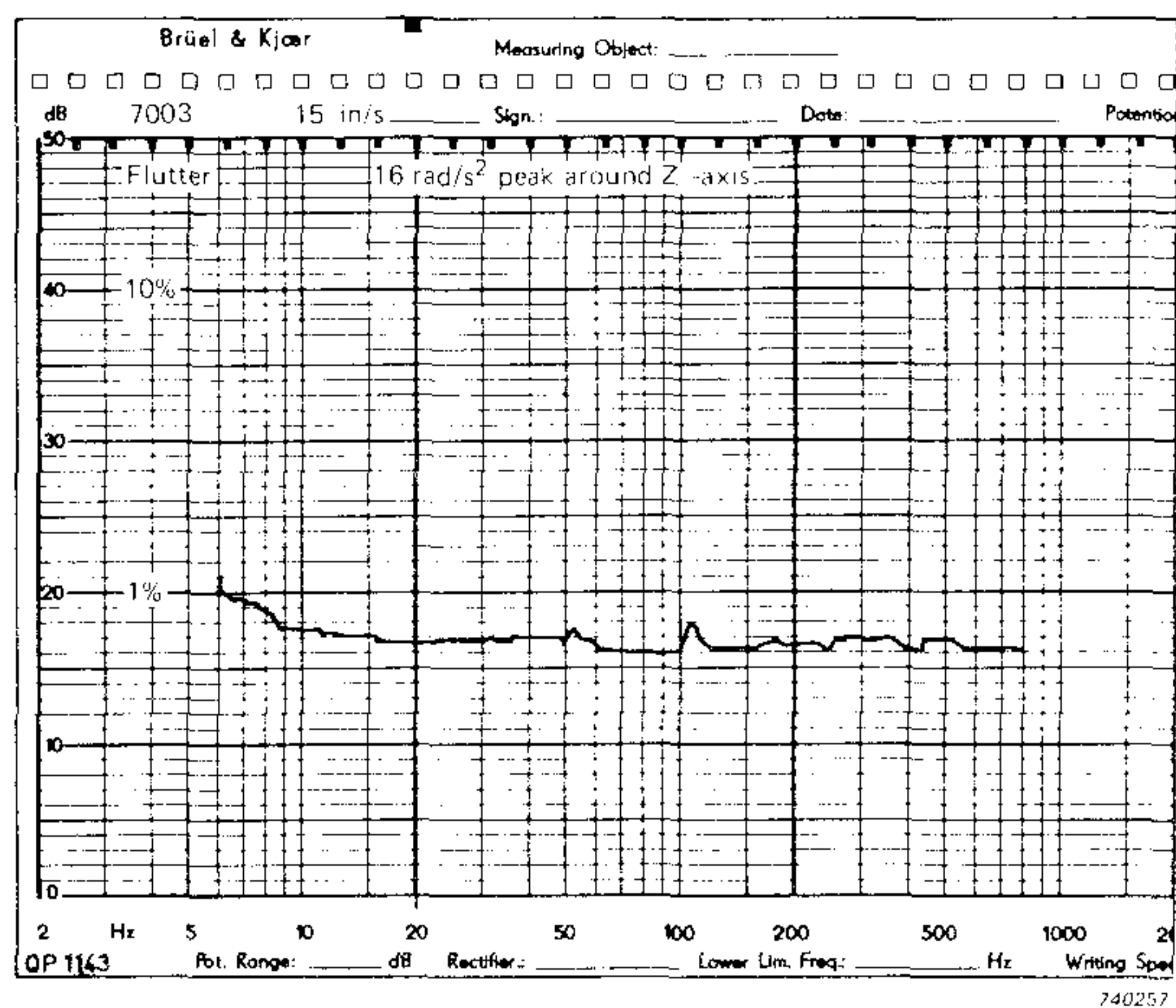

a

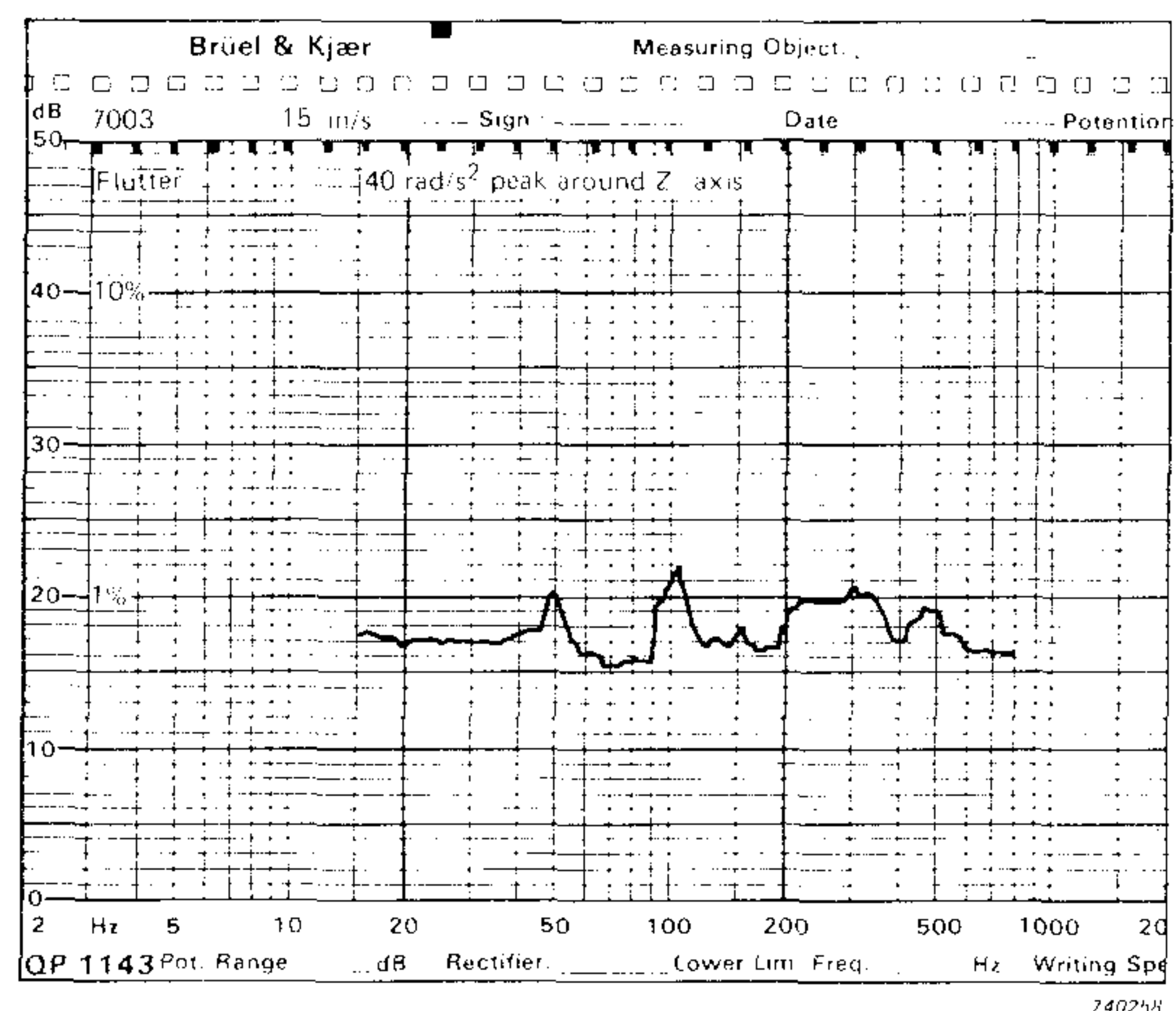

b

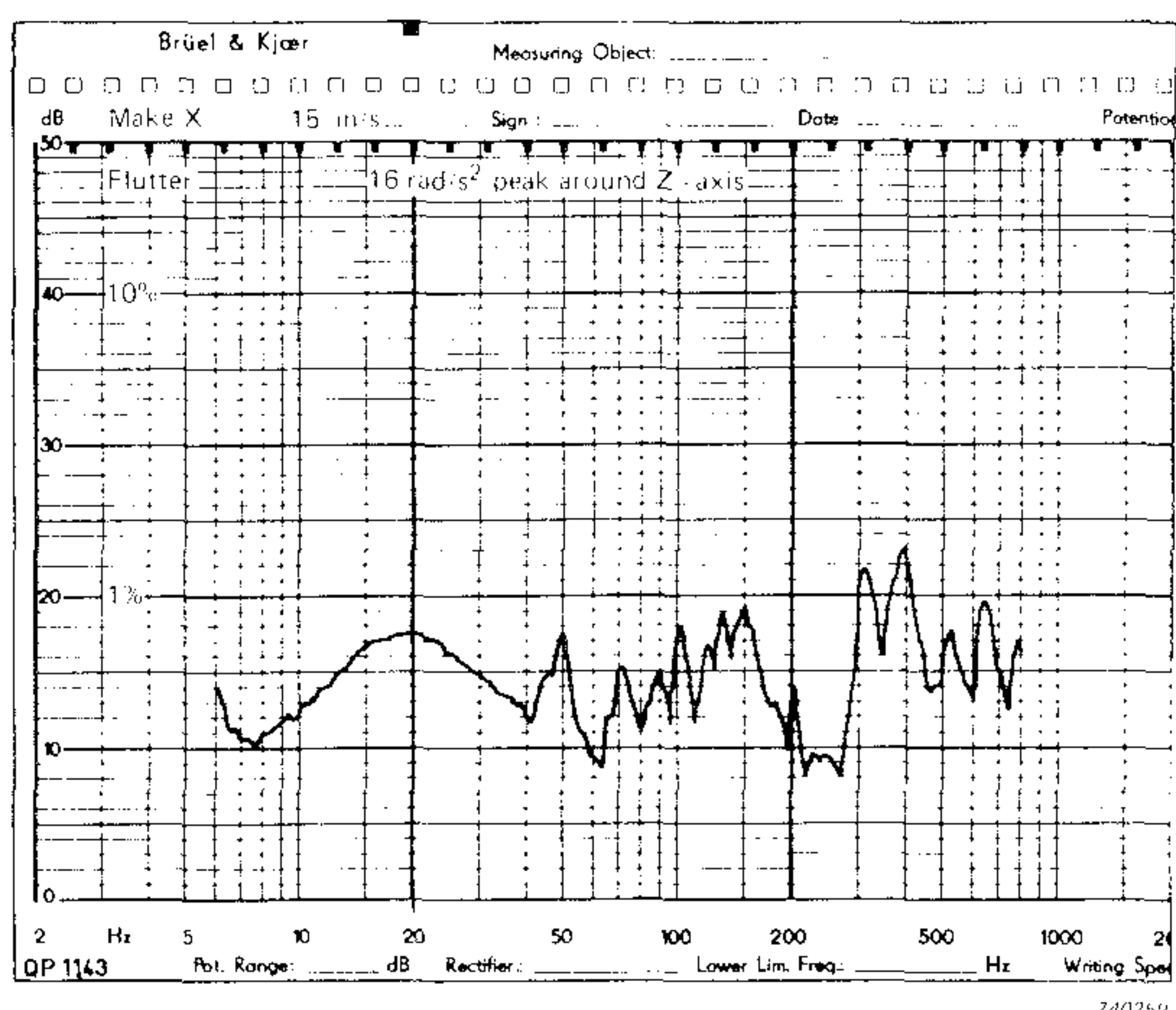

c

Fig.14. Flutter curves for rotational vibration for the two tape recorders playing back at 15 in/s
a. 16 rad/s² peak on 7003
b. 40 rad/s² peak on 7003
c. 16 rad/s² peak on Make X

Discussion of the measured results

From the results it can be seen that measurements can be carried out with the Tape Recorder Type 7003 within reasonable tolerances in a vibrational environment.

However, it is seen from the results that for both tape recorders an increase in flutter level is experienced both for rectilinear vibrations and for torsional vibration. This effect is considerably less for the 7003.

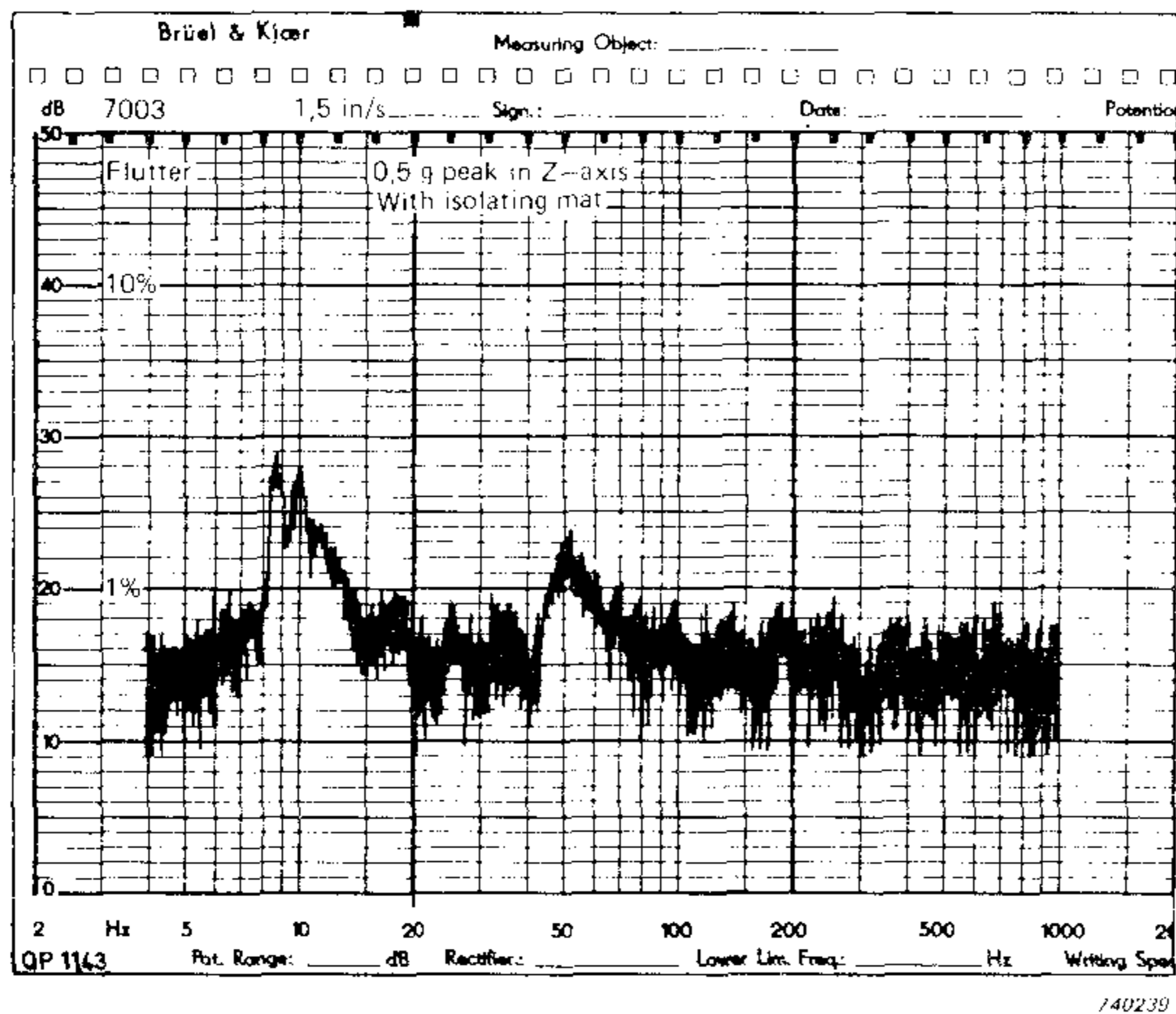

Fig.15. Flutter level of 7003 under the same conditions as in Fig.8 except with an isolating mat between the vibration fixture and the tape recorder. Note that on account of resonant amplification the vibration level is more than 1 g at approximately 10 Hz

For operation of the 7003 at 1,5 in/s, however, significant flutter levels and thereby reduction in signal-to-noise ratio may be expected when the vibration levels (at certain frequencies) approach 0,5 g peak which is given as the maximum recommended permissible value.

If greater demands on signal-to-noise ratio and flutter are placed the higher tape speed 15 in/s should be used, or in some applications the tape recorder may be isolated by placing it on an isolating mat. Comparing Fig.15 and Fig.8d, it can be seen that it is possible to reduce the flutter level (for relatively high frequency vibration, here above 40 Hz) by placing the tape recorder on one of the fibre mats used in the 7003 transport packing. However, a low frequency resonance is created (determined by the tape recorder mass and the stiffness of the mat) around which the flutter level is found to increase.

The Tape Recorder Type 7003 can be seen to be similarly influenced to some extent by angular accelerations of 16 rad/s^2 when operating at 1,5 in/s. When the tape speed is raised to 15 in/s considerably lower flutter values are recorded, even for 40 rad/s^2 .

Comparison with the Tape Recorder Make X reveal that although this tape recorder has very fine operational data when no vibration is present the 7003 shows superior operation in a vibrational environment. This is the case both for operation at 1,5 in/s and at 15 in/s although the operation for both tape recorders is much improved at the higher operational speed.

It should be noted that the Tape Recorder Type 7003 used for flutter measurements had been used extensively for approximately 2 years, of-

ten in rough environments. Therefore slightly better results should be expected, and are found, for a completely new model. However, the Tape Recorder Make X *was* completely new.

Conclusion

The Tape Recorder Type 7003 has proved to be relatively insensitive to vibration during operation. This is partly due to the use of differential capstans which reduce undesired motions of the tape while passing the record and reproduce heads, and partly to the search for and elimination of vibration sensitive details in the development and construction stages of the tape recorder.

The insensitivity of the Tape Recorder Type 7003 to a vibrational environment can be considered to be a significant asset especially during field use where the tape recorder must be placed on vibrating surfaces or where it is carried along by a person during recording.

News from the factory

Precision Conditioning Amplifier Type 2650

This calibration amplifier is equipped with 4 digit conditioning network which directly shows the sensitivity of the transducer under calibration when used together with a reference transducer, amplifier channel (Type 2626) and the sensitivity Comparator Type 2970.

The amplifier is able to work both as a voltage and a charge preamplifier. Depending on the transducer sensitivity the output sensitivity can be chosen between 0,001 V/unit and 100 V/unit in steps of 10. Two signal level indicators are provided. One indicates overload at both the input and the output stages while the other indicates when the signal is within 20 dB of full output revealing best signal to noise ratio.

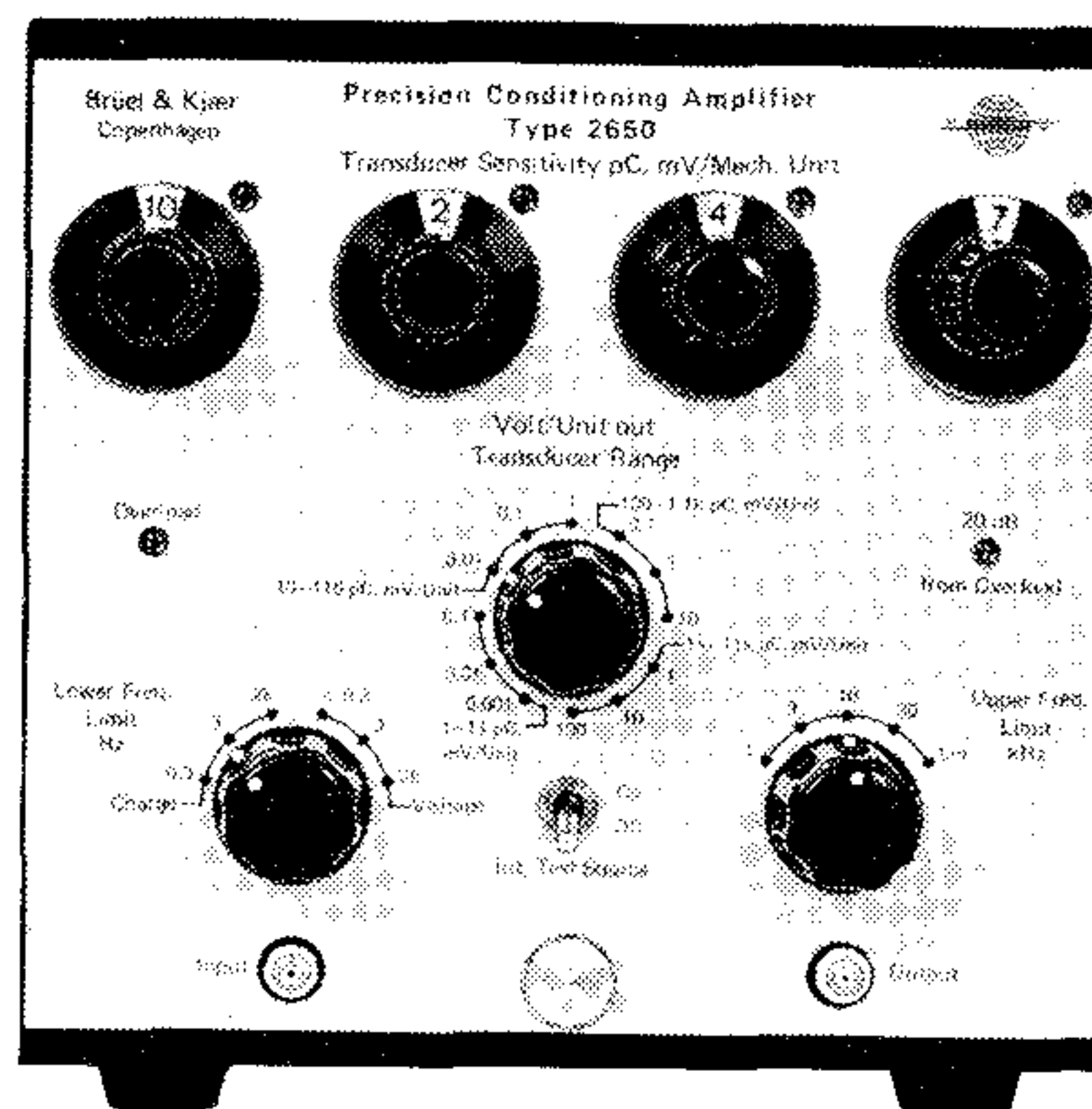

The frequency range of the amplifier can be limited by active high pass and low pass filters both of which have cut-off slopes of 12 dB/octave. The upper limiting frequencies can be chosen between 1, 3, 10 and 30 kHz while the lower limiting frequencies between 0,3 and 3 Hz. Also a 2 kHz high pass filter is included for use with hydrophones where low frequency noise could be troublesome when calibration is carried out in water tanks. Other features of the amplifier are short recovery time and a built in 1 kHz test oscillator.

Real-Time Narrow Band Analyzer Type 3348

The Real-Time Narrow Band Analyzer is a hybrid measuring system operating on the time compression principle. It produces a 400 channel constant bandwidth calibrated spectrum which is updated every 45 ms.

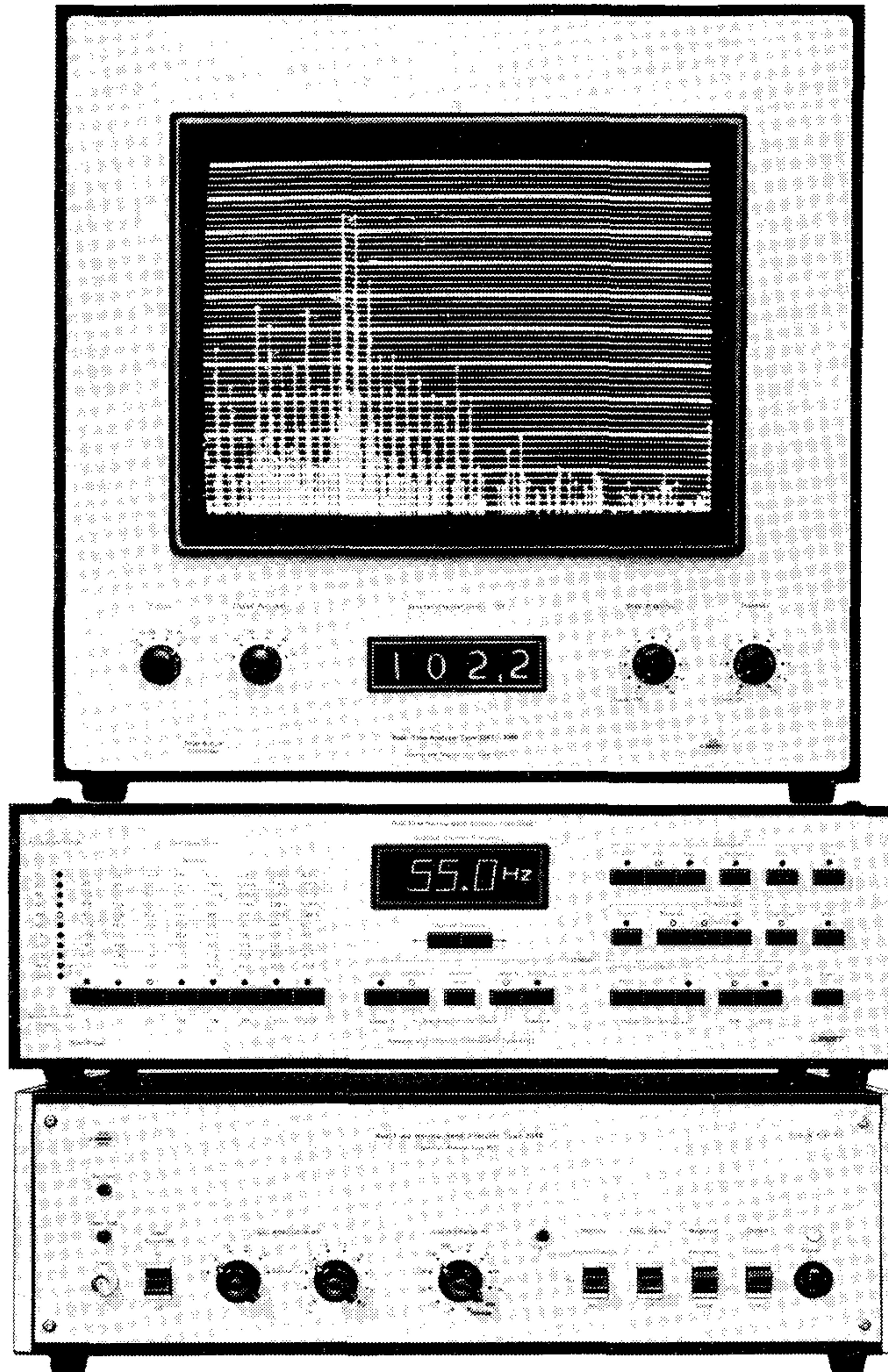

Eleven frequency ranges can be selected internally between 0 to 10 Hz and 0 to 20 kHz in a 1 — 2 — 5 sequence and real time is achievable up to 10 kHz. The bandwidth between each measuring channel would then be the highest frequency of the range selected, divided by 400, giving frequency resolutions between 0,025 and 50 Hz for the two extreme ranges. When external sampling control is used the frequency range can be made floating to conveniently enable tracking of a variable frequency.

Averaging of spectra can be carried out either linearly or exponentially. In the linear mode the number of spectra to be averaged can be selected between 8 and 1024 in a binary sequence, while 8 different effective averaging times can be selected for each frequency range for exponential averaging.

A store max. function is included as well as transient capture function whereby short duration signals and shocks can be registered and analyzed.

The spectra produced by the analyzer can be stored into either of two Display Memories, the contents of which may be displayed on the screen either individually or alternately. Thus immediate comparison between past and present spectra, averaged and instantaneous spectra, etc. is possible. The level and frequency of any channel can be read off conveniently from the respective digital displays utilizing the channel selector.

For error free operation the controls of the analyzer are electronically interlocked, while important functions can also be externally controlled by, for example, an on-line computer.

The dynamic range of the Analyzer is 50 dB nominally, though a further + 12 dB gain is achievable after averaging and before display.

Analogue output is available for X-Y and Level Recorders, while digital output is available for on-line operation with computers or for other digital peripherals.

By connecting directly the Frequency Analyzer Type 2130, Real Time 1/3 octave and narrow band analysis can be achieved simultaneously by means of a push-button.

The analyzer features mentioned above open up measurement possibilities in wide fields of application which hitherto have been forbidding from a time point of view. The immediate uses of the analyzer can be readily seen in the fields of speech analysis, phonetics, Real Time vibration, acoustic, shock and order analysis. Its use in physiological and neurological research as well as trouble shooting and maintenance where Real Time analysis is a great asset should neither be overlooked.



BRÜEL & KJÆR

Real Time Signal Analysis

Brüel & Kjær Instrumentation

Examples of Application

BRÜEL & KJÆR

Automatic Random and Shock Vibration Test

REAL TIME SIGNAL PROCESSING

Vibration and Shock Measurement and Analysis

Audiometer Calibration Hearing Aid Testing

SHORT FORM CATALOGUE

Sound, Vibration and Data Analysis Instrumentation

Standards, Formulae and Charts

POWER SPECTRAL DENSITY MEASUREMENTS

4311

4801

ACOUSTIC NOISE MEASUREMENTS

1519

Описание и Применение

2305

BRÜEL & KJÆR

DK-2850 Nærum, Denmark. Teleph.: (01) 80 05 00. Cable: BRUKJA, Copenhagen. Telex: 15316